



SIBER HRV/ERV EVO



Installation & User Manual

SUMMARY

1 DELIVERY	3
1.1 CONTENTS OF THE DELIVERY	3
1.2 OPTIONAL ACCESSORIES FOR SIBER EVO	4
2 APPLICATION	5
2.1 PREHEATER	5
3 MODEL	6
3.1 TECHNICAL SPECIFICATIONS	6
3.2. CHARACTERISTIC CURVES	7
3.3 CONNECTIONS AND DIMENSIONS	9
3.4 EXPLODED VIEW OF THE UNIT	10
4 OPERATION	11
4.1 DESCRIPTION	11
4.2 BY-PASS CONDITIONS	11
4.3 ANTI-ICE SECURITY	11
5 INSTALLATION	12
5.1 GENERALALITIES	12
5.2 POSITION OF THE UNIT	12
5.3 CEILING MOUNTING	13
5.4 WALL MOUNTING	15
6 NOZZLE ORIENTATION	17
7 CONNECTION OF THE CONDENSATE DRAIN	19
8 CHANGE OF FILTERS	20
9 ELECTRICAL CONNECTION	21
9.1 MAINS CONNECTION	21
10 MONITOR YOUR HOME - PROBES / WIRELESS CONTROLS	23
11 SMART CONNECTIVITY	24
11.1 MODBUS - RS485	24
11.2 KNX - EVO CONNECT	24
11.3 BRIDGE ETHERNET - SIBER EVO APP	25
12. MAINTENANCE	26
12.1 FILTER MAINTENANCE (FOR THE USER)	26
12.2 MAINTENANCE OF THE HEAT EXCHANGE (FOR THE INSTALLER)	27
12.3 EXPLODED VIEW AND DESCRIPTION	29
CERTIFICATE OF GUARANTEE	30

1 DELIVERY

1.1 CONTENTS OF THE DELIVERY

Before starting the installation of the Dual Flow VMC Unit with Thermal Energy Recovery, you should check whether it has been delivered complete and intact.

The delivery content of the VMC SIBER EVO 1/2 unit consists of the following items:

1. **MVHR unit with Thermal Energy Recovery SIBER HRV EVO 1/2 or SIBER ERV EVO 1/2**
2. **Installation Manual**
3. **Eco design label**
4. **Installation guides**
5. **Bag with silentblocks and screws**

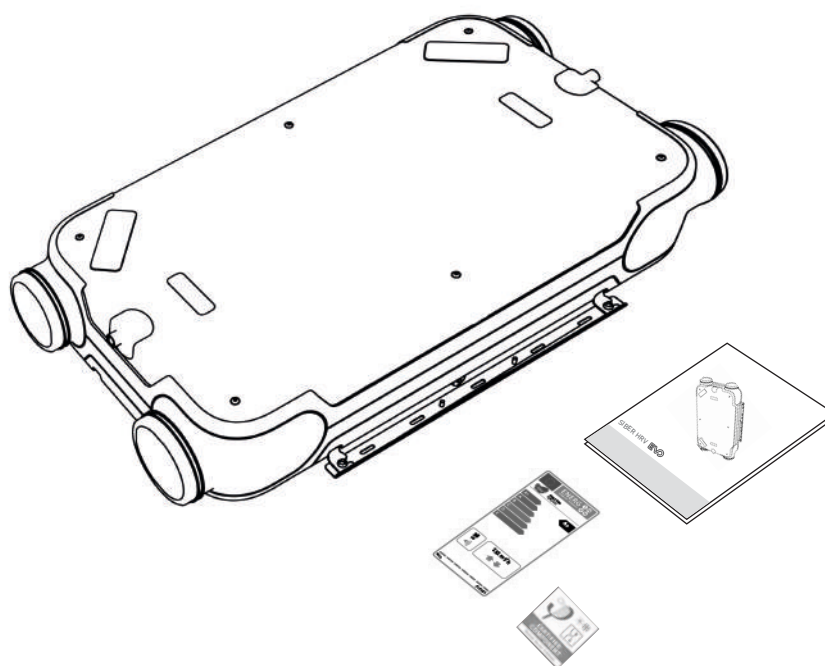

Unit supplied without regulating control [\[see section 1.2 for optional accessories\]](#)

* If the Unit has been delivered with any visible defects, such as dents or scratches, or if all the items and accessories listed above are not included, please contact your supplier.



The use of this Unit is not authorised for persons, including minors, with reduced intellectual capacities, limited physical capacities, or lack of experience and necessary knowledge, unless they are under the supervision of, or have been instructed by a person responsible for their safety, in the use of the Unit.



In any case, children should be monitored to ensure that they do not play with the Unit.

1.2 OPTIONAL ACCESSORIES FOR SIBER EVO

DESCRIPTION	IMAGE	CODE
G4 FILTER COARSE 65%		DFFG4
F7 FILTER ePM1 55%		DFFF7
G4 + F7 FILTER COARSE 65% - ePM1 55%		DFFG4F7
CARBON FILTER		DFFCA
F9 FILTER ePM1 80%		DFFF9
G4 + F9 FILTER COARSE 65% - ePM1 80%		DFFG4F9
Wireless 4-position pushbutton control		DFPULS4B
Wireless smart multi-control		DFEVOCTRL
Wireless smart humidity sensor		DFEVOHR
Wireless smart CO2 sensor		DFEVOC02
RF - Ethernet communication gateway		DFEVORFETH
RF - RS485 Communication Gateway		DFEVORFRS485
Connect Modbus master KNX converter		DFEVOCONNECT
Siber EVO APP Smart monitoring of equipment and indoor air quality		Connectivity via Ethernet gateway (DFEVORFETH)

2 APPLICATION

The SIBER EVO 1/2 is a Double Flow Controlled Mechanical Ventilation Unit with a Thermal Energy Recovery Unit with an efficiency of up to 95%, a maximum ventilation capacity of 150 m³/h for the SIBER EVO 1 and a maximum capacity of 200 m³/h for the SIBER EVO 2; with low energy consumption fans for both units.

Characteristics of the SIBER EVO 1/2 unit:

- 600W preheater at the fresh air intake that raises the temperature up to 10°C.
- Continuous regulation of air flows by means of the control panel.
- Presence of a filter status indicator on the Unit and the possibility of filter status indication on the position selector.
- New smart anti-icing regulation ensures that the unit continues to operate optimally even at low temperatures. If necessary, switch on the pre-heating (included).
- Low noise level.
- Equipped as standard with a by-pass valve with automatic operation.
- Constant flow regulation.
- Energy saving.
- High Performance.

The SIBER EVO 1/2 is available in 4 versions:

- **SIBER HRV EVO 1**
- **SIBER HRV EVO 2**
- **SIBER ERV EVO 1**
- **SIBER ERV EVO 2**

These installation instructions apply to both the SIBER HRV EVO 1/2 and the SIBER ERV EVO 1/2.

The SIBER EVO 1/2 units can be wall or ceiling mounted, with the standard fixing brackets included. For the correct position of the duct connections and their dimensions [\[see section 3.3\]](#).



Important! For the correct efficiency of the ventilation system, it is recommended not to disconnect the unit, except for maintenance

2.1 PREHEATER



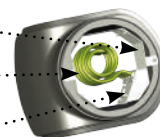

The preheater protects the heat exchanger in the ventilation unit during the cold season.





- ✓ Frame is made from AluZinc coated steel, which is highly resistant to corrosion ○
- ✓ Heating elements are made from stainless steel AISI304. Power output 0.6kW ○
- ✓ Equipped with automatic protection thermostat set to 40°C which prevent overheating ○



3 MODEL

3.1 TECHNICAL SPECIFICATIONS

SIBER HRV EVO 1 & ERV EVO 1					
Mains voltage	230 V/ 50 Hz				
Degree of protection	IP 40				
Dimensions (l x h x d)	1000 x 600 x 210 mm				
Connection diameter	160 Ø				
Condensate drain diameter	1/2"				
Weight	24 Kg				
Filter class	Coarse 65% (G4)				
Fan position (standard)					Boost mode
Wireless Smart Multi-Controller (optional)	0	1	2	3	Maximum
Ventilation flow rate (m ³ /h)	30	75	100	140	150

SIBER HRV EVO 2 & ERV EVO 2					
Mains voltage	230 V/ 50 Hz				
Degree of protection	IP 40				
Dimensions (l x h x d)	1000 x 600 x 210 mm				
Connection diameter	160 Ø				
Condensate drain diameter	1/2"				
Weight	24 Kg				
Filter class	Coarse 65% (G4)				
Fan position (standard)					Boost mode
Wireless Smart Multi-Controller (optional)	0	1	2	3	Maximum
Ventilation flow rate (m ³ /h)	30	75	100	150	200

3.2. CHARACTERISTIC CURVES

SIBER® HRV EVO 1 & ERV EVO 1

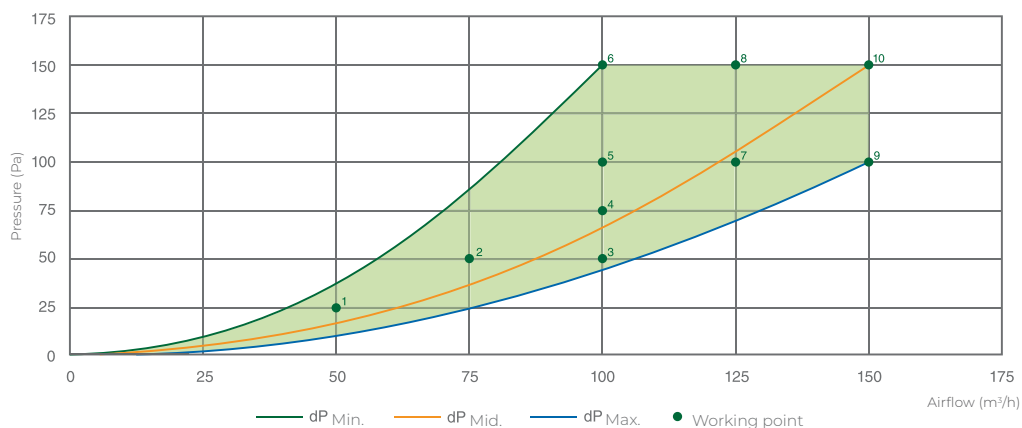
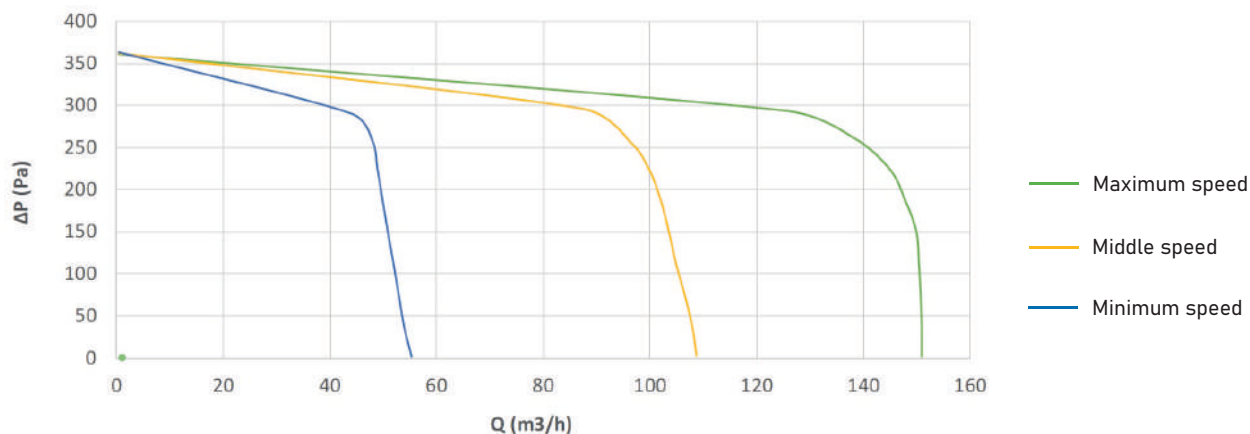

Working points	AIRFLOW (m³/h)	PRESSURE (Pa)	POWER (W)	SFP (W/l/s)
1	50	25	9.24	0.67
2	75	50	15.37	0.74
3	100	50	20.55	0.74
4	100	75	24.52	0.88
5	100	100	28.87	1.04
6	100	150	37.62	1.35
7	125	100	37.13	1.07
8	125	150	46.07	1.33
9	150	100	48.14	1.16
10	150	150	58.25	1.40

Sound level SIBER® HRV EVO 1 & ERV EVO 1

Ventilation flow rate (m³/h)		50	75	100	150		
Sound level Lw (A)	Static pressure (Pa)	25	50	50	100	100	150
	Box irradiation (dB(A))	24	34	38	44	45	49
	Extraction duct (dB(A))	28	30	39	42	46	47
	Insufflation duct (dB(A))	42	50	53	56	61	64

SIBER® HRV EVO 2 & ERV EVO 2

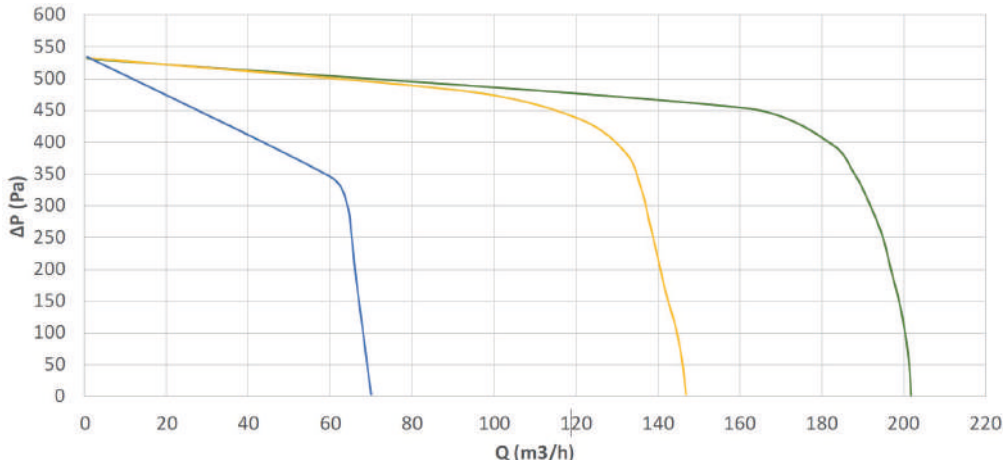

- Maximum speed
- Middle speed
- Minimum speed

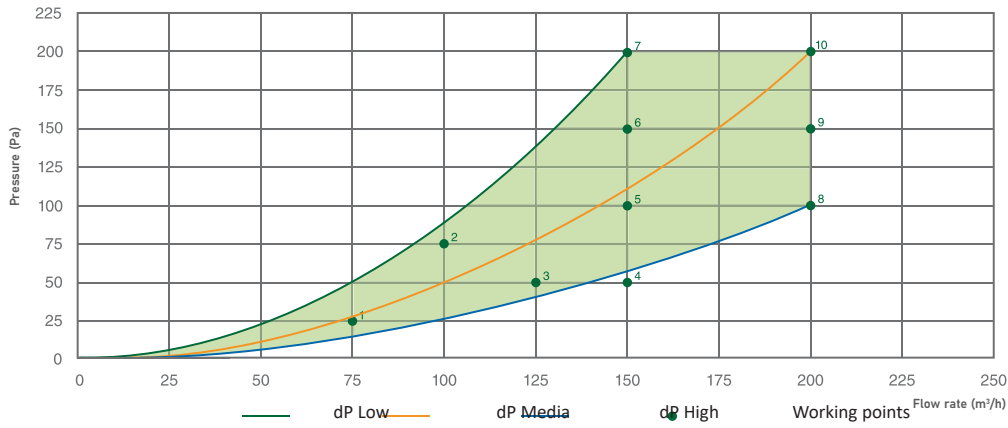

Working points	AIRFLOW (m³/h)	PRESSURE (Pa)	POWER (W)	SFP (W/l/s)
1	75	25	12.61	0.61
2	100	75	25.31	0.91
3	125	50	29.16	0.84
4	150	50	39.20	0.94
5	150	100	49.65	1.19
6	150	150	60.92	1.46
7	150	200	72.60	1.74
8	200	100	81.33	1.46
9	200	150	93.10	1.68
10	200	200	106.48	1.92

Sound level SIBER® HRV EVO 2 & ERV EVO 2

Ventilation flow rate (m³/h)		75	125	150	200		
Sound level Lw (A)	Static pressure (Pa)	25	50	50	100	150	200
	Box irradiation (dB(A))	33	42	44	46	51	56
	Extraction duct (dB(A))	34	43	45	48	50	57
	Insufflation duct (dB(A))	46	51	59	62	65	66

3.3 CONNECTIONS AND DIMENSIONS

SIBER EVO

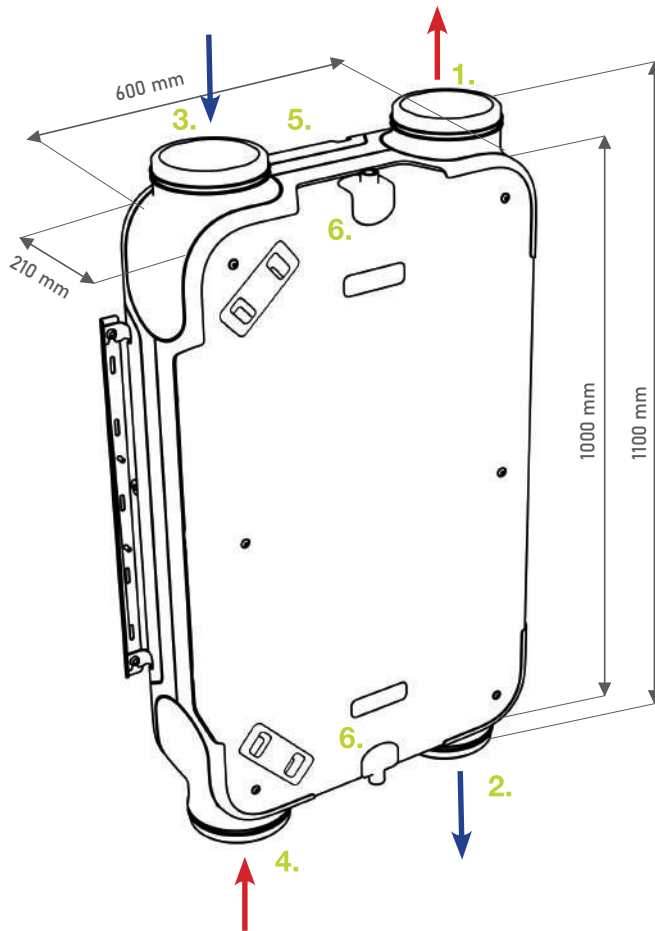

LEGEND STANDARD VERSION

1	Exhaust air
2	Fresh air supply to the dwelling
3	Fresh air intake from outside
4	Extraction of stale air from inside the dwelling
5	Electrical connection
6	Condensate drain connection

3.4 EXPLODED VIEW OF THE UNIT

SIBER EVO

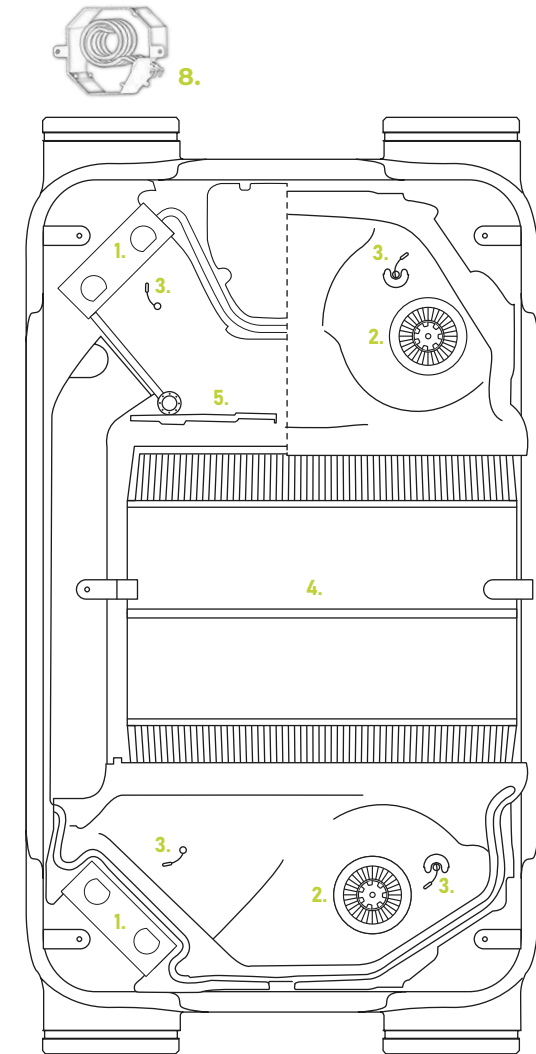

LEGEND

1	High performance filters
2	Energy-efficient engines
3	Temperature probes
4	High-performance heat exchanger
5	100% automatic bypass
6	Swivelling condensate drain
7	Electrical connections
8	Preheater

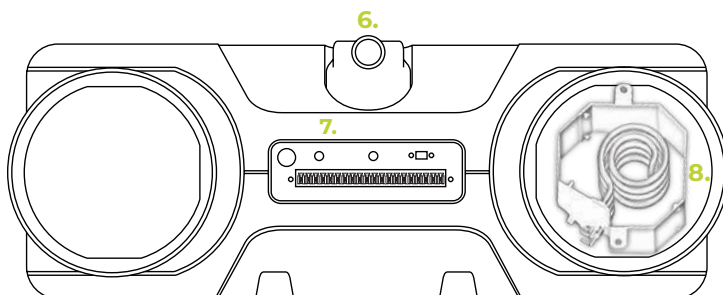

4 OPERATION

4.1 DESCRIPTION

The unit is delivered ready to be connected to the power supply and works fully automatically. The stale air extracted from inside transfers the thermal energy (calories/B.T.U.s) to the fresh air coming from outside. This saves energy in air-conditioning, as the new, clean air is blown into the house at a conditioned temperature (cool in summer, warm in winter).

Depending on the type of control unit used, up to 5 ventilation positions are possible. The air flow rate is regulated by the regulating position. Constant volume control allows the air flow rate of the supply and extract fans to be obtained independently of the duct pressure.

4.2 BY-PASS CONDITIONS

The By-Pass fitted as standard allows fresh air to be blown in directly from outside without passing through the heat exchanger, so that the comfort temperature outside at any given time can be used, for example on summer nights when it is desirable for fresh air to enter from outside to cool the inside of the house (free-cooling).

The by-pass valve is automatically activated when a certain number of conditions are met (see table below for by-pass values).

By-Pass gate conditions	
By-pass valve open	<ul style="list-style-type: none"> • The outside temperature is higher than 10°C. • In summer, the outside temperature is 3°C lower than the temperature of the air extracted from the home, and lower than the comfort temperature. • In winter, the outside temperature is 3°C higher than the temperature of the air extracted from the home, and higher than the comfort temperature.
By-pass valve closed	<ul style="list-style-type: none"> • The outside temperature is below 10°C. • In summer, the outside temperature is higher than the temperature of the air extracted from the home, and higher than the comfort temperature. • In winter, the outside temperature is lower than the temperature of the air extracted from the home, and lower than the comfort temperature.



The unit automatically detects the season (winter/ summer) and this will work according to the by-pass temperature selected.

4.3 ANTI-ICE SECURITY

To prevent the formation of ice in the heat exchanger at very low outdoor temperatures, the SIBER DF EVO 1/2 is equipped with anti-icing protection.

Thermostatic probes measure the temperatures in the heat exchanger and if necessary a progressive unbalance is set in the automatic equipment. Up to -16 degrees the Unit would stop and check every hour if the temperature is suitable for operation.

5 INSTALLATION

5.1 GENERALALITIES

The installation must be carried out in accordance with:

- Ventilation quality requirements for rooms (CTE HS3 - RITE 2007).
- Quality requirements for balanced ventilation of dwellings (CTE HS3).
- Requirements for the ventilation of rooms and dwellings (CTE HS3).
- Safety requirements for low voltage installations.
- Requirements for the connection of drains to sewage systems in the rooms and dwellings.
- Any additional requirements of local energy distribution companies.
- Installation instructions for the SIBER EVO 1/2 unit.

5.2 POSITION OF THE UNIT

The SIBER EVO 1/2 can be fixed directly to the wall or ceiling thanks to the fixing brackets included for this purpose



Warning! Depending on the weight of the Unit, the installation of the Unit should always be carried out by 2 persons.

For a vibration-free result, a wall or ceiling with a minimum mass of 200 kg/m² must be used as a suspension surface. It is not enough for the wall or ceiling to be made of concrete or metal structures. In these cases, additional measures will be necessary, such as double plate reinforcement or additional supports. The following points should be kept in mind:

- The Unit must be set level, both in length and width.
- The installation space should be chosen to allow for good condensate drainage, with a trap and a slope for condensate water.



Warning! Ensure that the condensate drain slope is not positive or parallel to the unit.

Warning! The unit is designed for wall or ceiling mounting only. Never install it directly on the floor.

- The installation space must be protected from the weather and frost.
- Ensure that there is sufficient space around and underneath the Unit to ensure that changing or cleaning the filter as well as maintenance of the Unit can be carried out properly

5.3 CEILING MOUNTING



- 1 Use the installation template, located on the back of the box

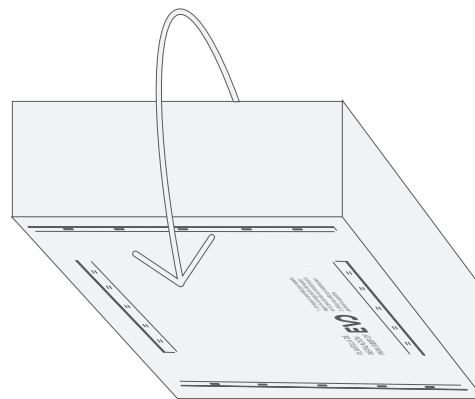

- 2 Mark the area where the fixing brackets are to be installed with the help of the installation template.

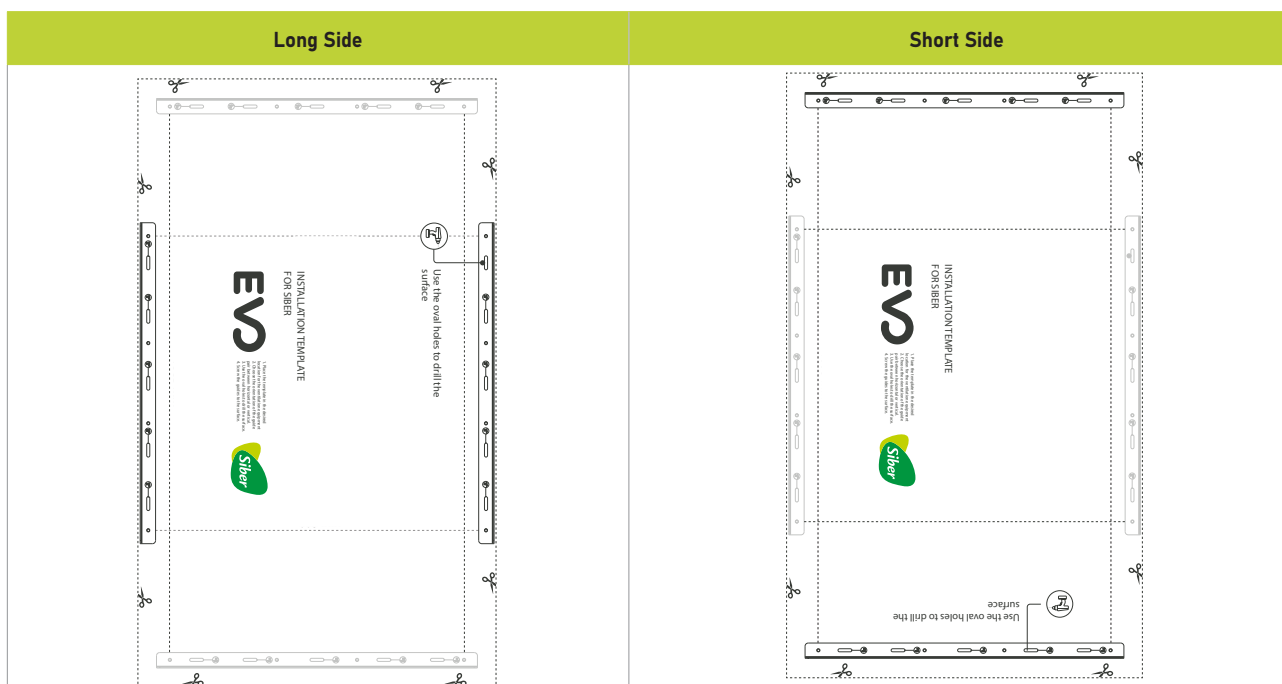

! If the template is not used, the fixing brackets must be spaced 630 mm apart on the long sides (standard version) and 1,035 mm apart on the short sides.

By default, the unit comes with the Silentblock Hooks fitted on the long side.
To switch to the short side, follow the steps below:

- 2.1 Unscrew the Silentblock Hooks

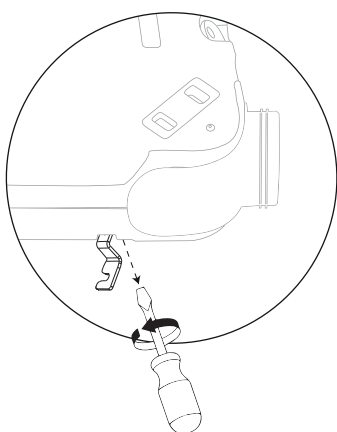

- 2.2 Replace the Silentblock Hooks to the short side, respecting the same direction.

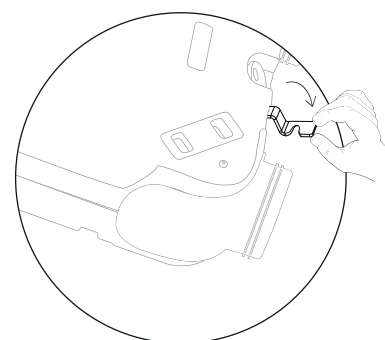
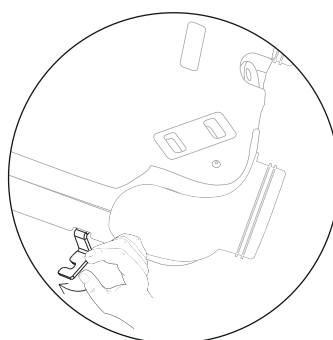

- 2.3 Screw the Silentblock Hooks into the desired new position.

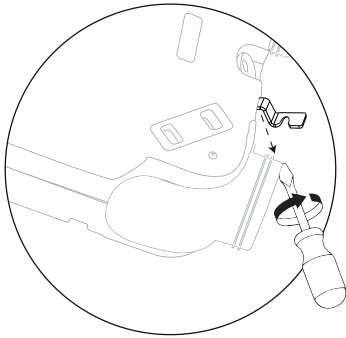

- 3 Drill the marked surface and screw the fixing brackets through the oval holes.

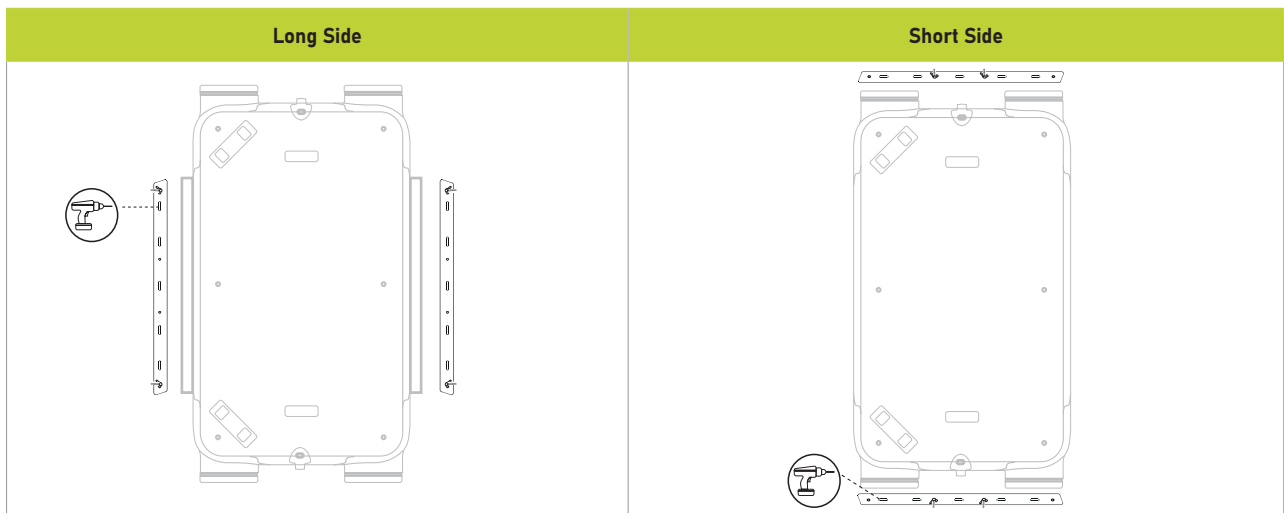

- 4 Loosen the wing-nuts and leave 1 cm of space

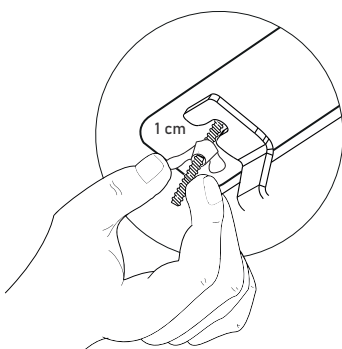

- 5 Place on top of the guide and slide until it engages with the threaded rod.

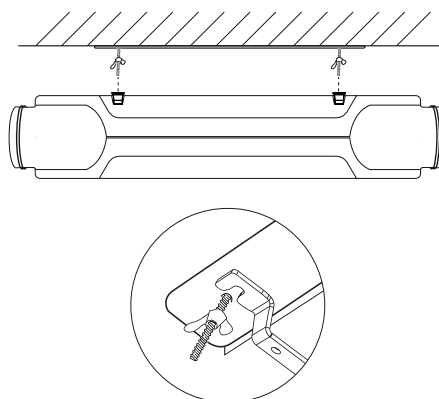

- 6 Tighten the wing-nuts

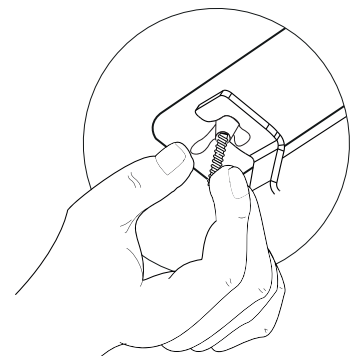

5.4 WALL MOUNTING



- 1 Use the installation template, located on the back of the box

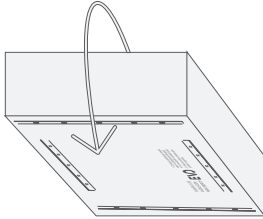

Attention!

When installed on the wall, the unit must be always installed in vertical position for allowing a proper water draining through the collection pipe

Attention!

In vertical installation, place the PCB connector at top position. The PCB must never be at bottom position

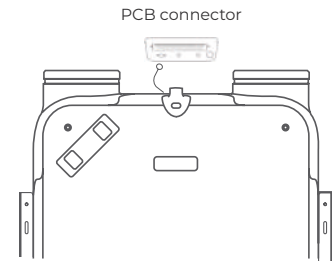

- 2 Mark the area where the fixing brackets are to be installed with the help of the installation template.

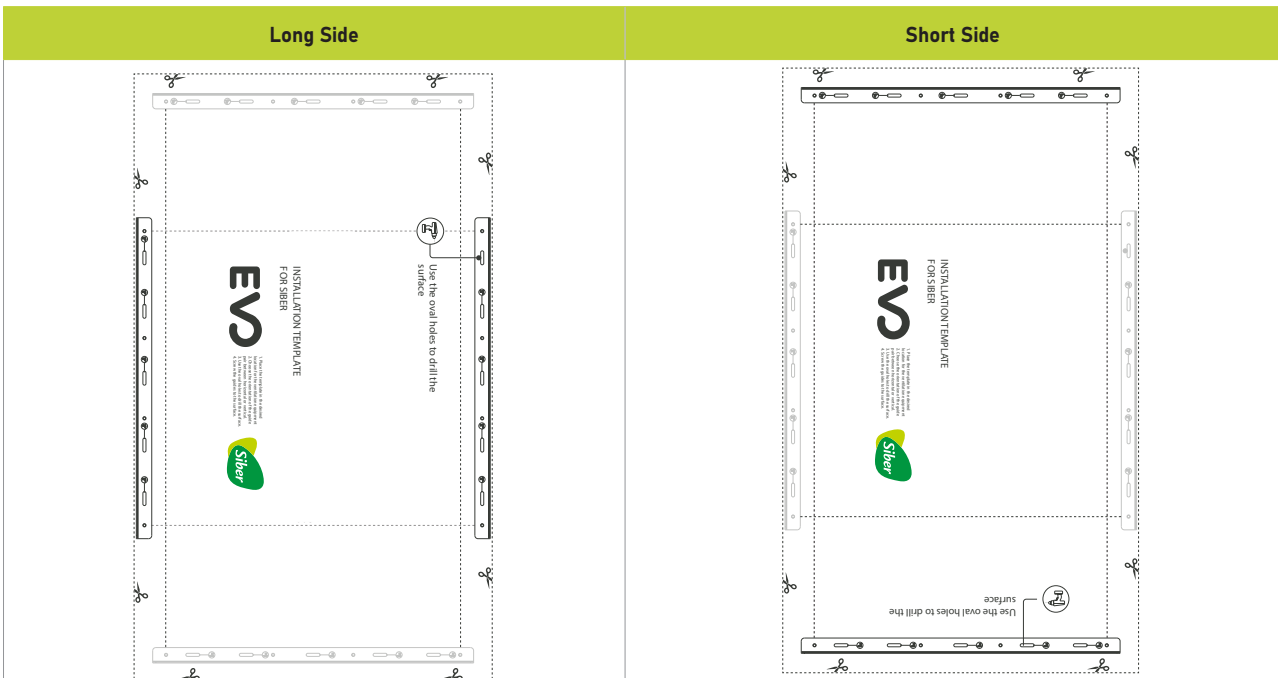

If the template is not used, the fixing brackets must be spaced 630 mm apart on the long sides (standard version) and 1,035 mm apart on the short sides.

By default, the unit comes with the Silentblock Hooks fitted on the long side.
To switch to the short side, follow the steps below:

- 2.1 Unscrew the Silentblock Hooks

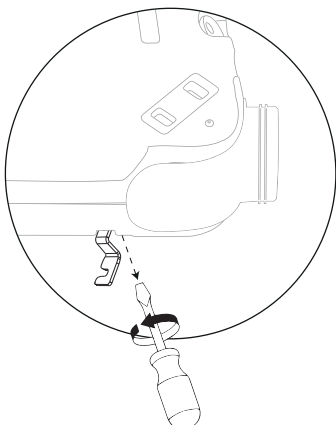

- 2.2 Replace the Silentblock Hooks to the short side, respecting the same direction.

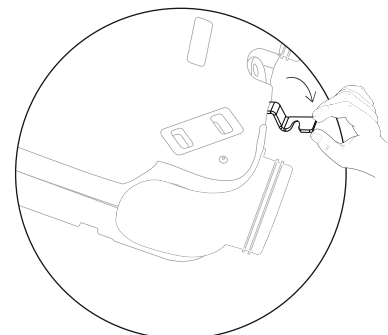
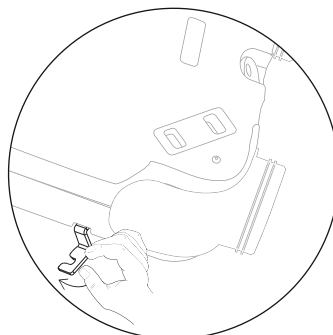

- 2.3 Screw the Silentblock Hooks into the desired new position.

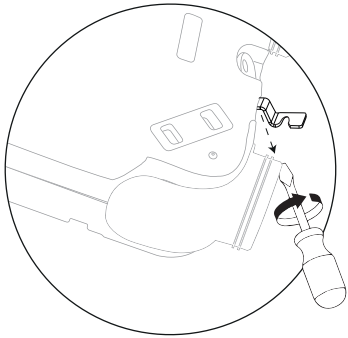

- 3 Drill the marked surface and screw the fixing brackets through the oval holes.

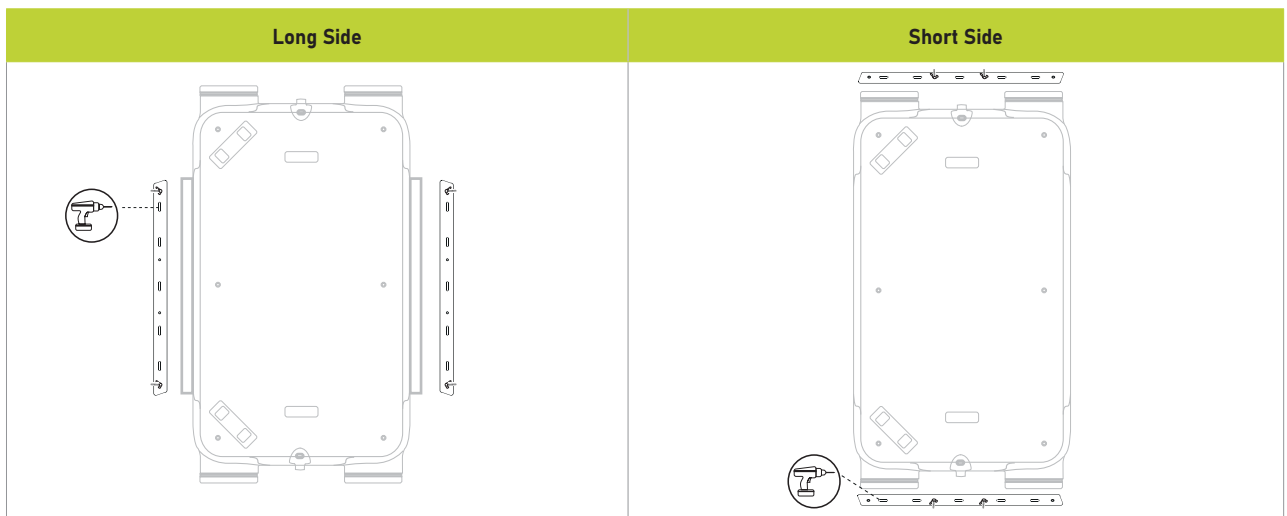

- 4 Loosen the wing-nuts and leave 1 cm of space

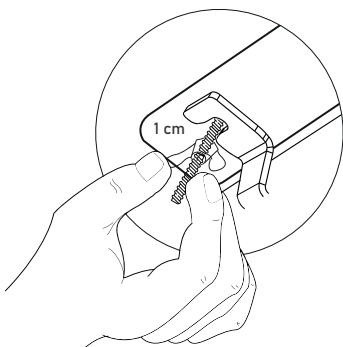

- 5 Place on top of the guide and slide until it locks into place with the wing-nutsl.

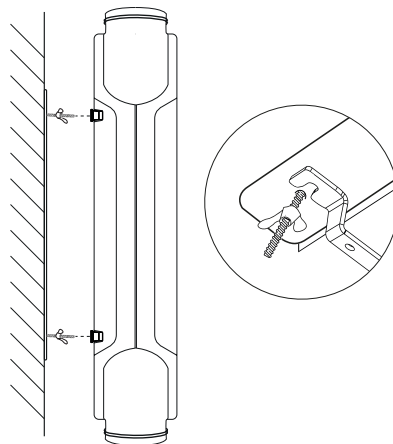

- 6 Tighten the wing-nuts

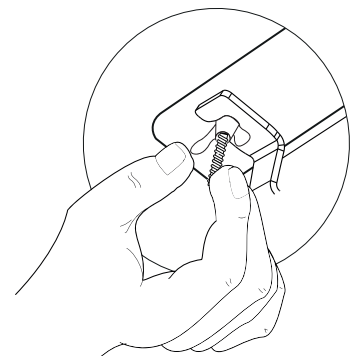

6 NOZZLE ORIENTATION

To change the default direction of the nozzles, follow the steps below:

- 1 Remove the filter covers

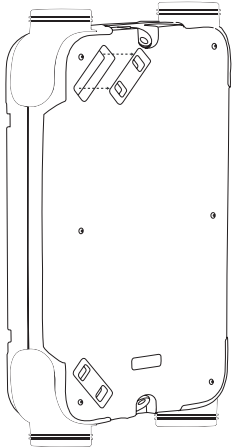

- 2 Unscrew the outer cover

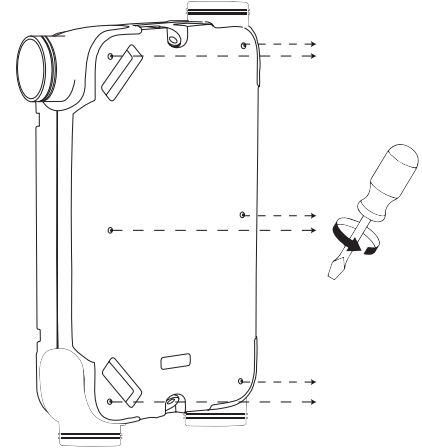

- 3 Remove the outer cover and the front polypropylene of the Unit, leaving the interior exposed

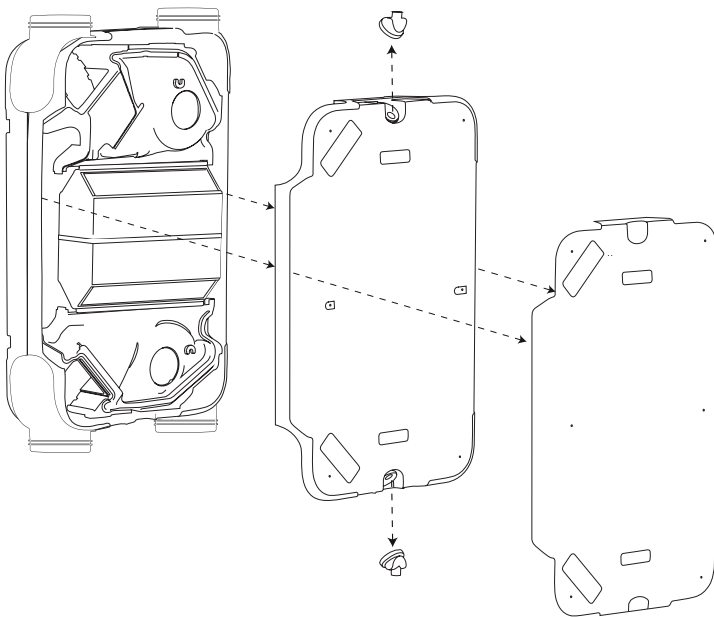

- 4 Unscrew the nozzle from the back side

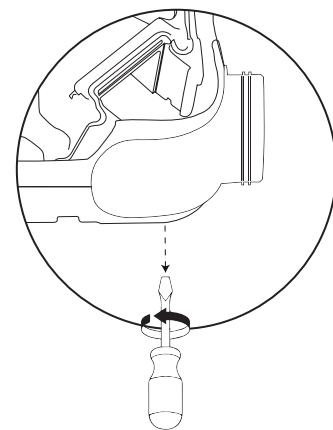

5 Raise the nozzle

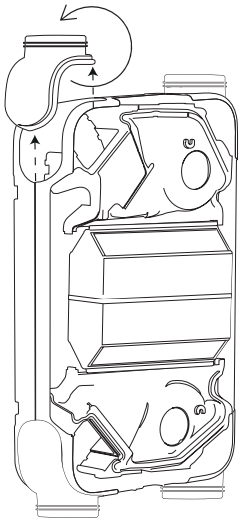

6 Turn the nozzle

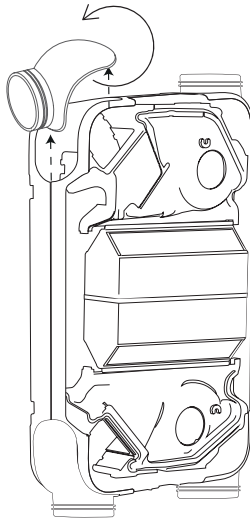

7 Screw the nozzle back on again from the back.

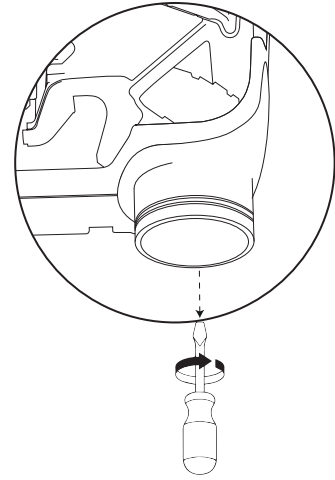

8 Fit the outer and inner covers of the Unit

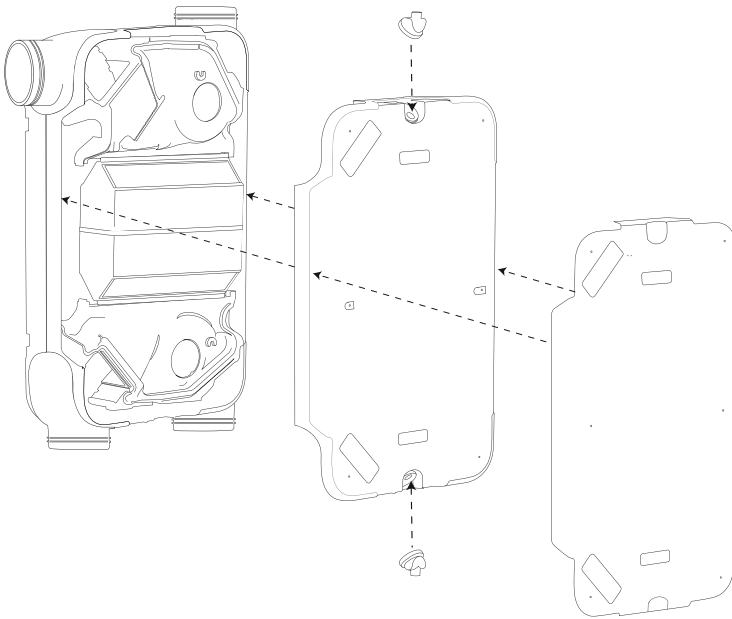

9 Screw on the outer cover

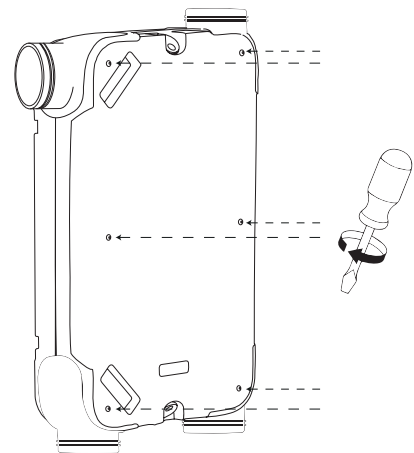

10 Replace the filter covers

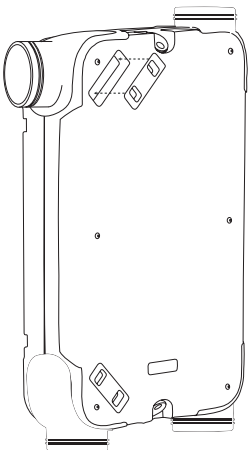

7 CONNECTION OF THE CONDENSATE DRAIN

The **SIBER HRV EVO 1/2** must always be fitted with a condensate drain. Condensation water must be drained off.

The 1/2" male threaded condensate drain connection fitting (not included with the Unit) must be screwed by the installer into the condensate tank of the Unit.

! Important! Always use a detachable condensate drain connection between the trap and the unit for proper maintenance.

The condensate drain pipe can be fitted underneath. The installer can adjust the condensate drain into the desired position. The drain must end at the trap water level.

Use a 32 mm diameter condensate drain pipe.

! In the case of a ceiling installation, make sure that the condensate drainage is below the level of the SIBER HRV EVO 1/2.

! Note: Only one condensate drain is connected, the other drain must remain closed with the plug. In the case of the Siber ERV EVO 1/2 (Enthalpic), the two drains must be closed with two plugs, it is not necessary to connect to the condensate drain.



! Note:

In the case of ceiling installation: Install the condensate trap in the drain on the side of the ducts leading to the outside. The other drain should be covered with the plug.

In the case of a wall installation: Install the condensate trap in the bottom drain of the device. The other drain should be covered with the plug.



! Attention! For the equipment warranty to remain valid, it is necessary to install a dry siphon (Dry Ball Siphon or Dry Flexible Siphon).

If the evacuation of condensates is executed in another way and there is any unforeseen event in the After-sales related to the evacuation of condensates, Siber is excluded from any responsibility, and it will be the responsibility of the installation company that has carried out the installation to solve any problem and the costs derived from this problem.

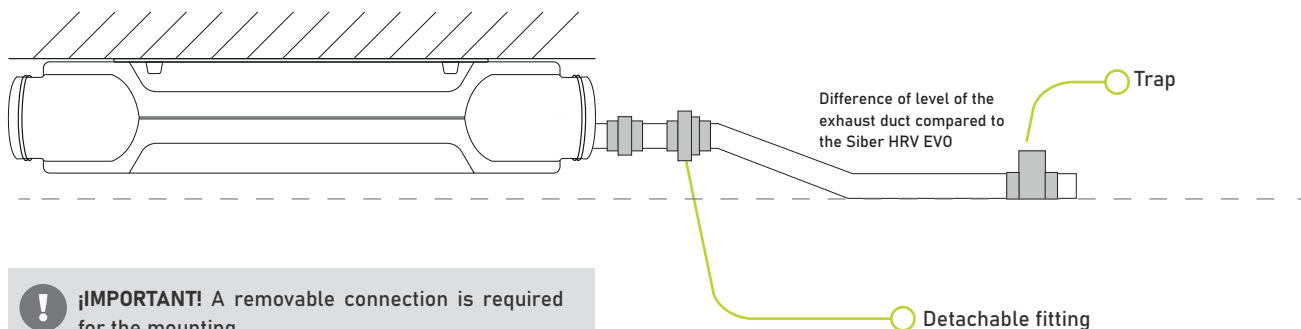

! ¡IMPORTANT! A removable connection is required for the mounting.

8 CHANGE OF FILTERS

1 Remove the filter cover.

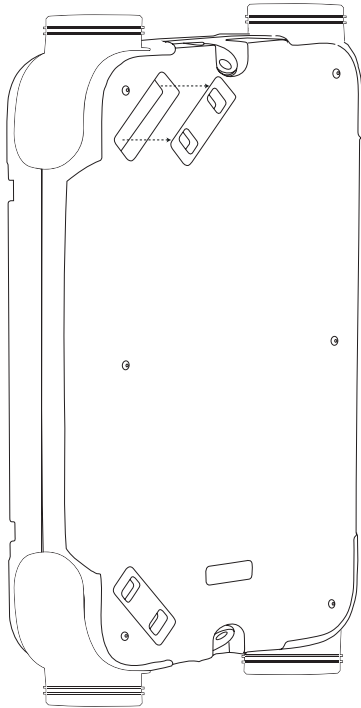

2 Pull the filter outwards.

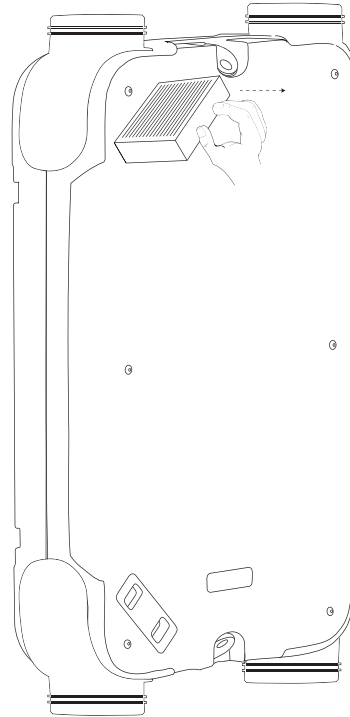

3 Place the new filter in the slot and push it in.

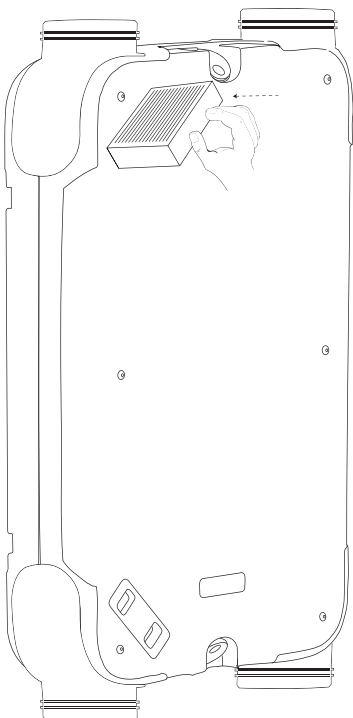

4 Replace the filter covers

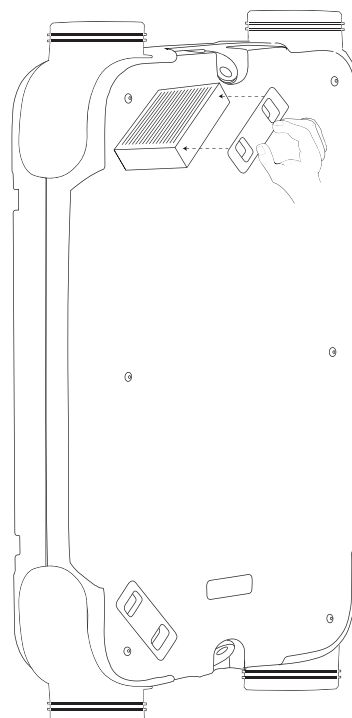

9 ELECTRICAL CONNECTION

9.1 MAINS CONNECTION

The electrical installation must correctly comply with the relevant standards.

Warning! The fans and the control circuit shall operate at 230 V. If handling or maintenance work is carried out, the unit must be disconnected from the mains.

HOSE IDENTIFICATION COLOURS	
BROWN	Line
BLUE	Neutral
GREEN / YELLOW	Earth

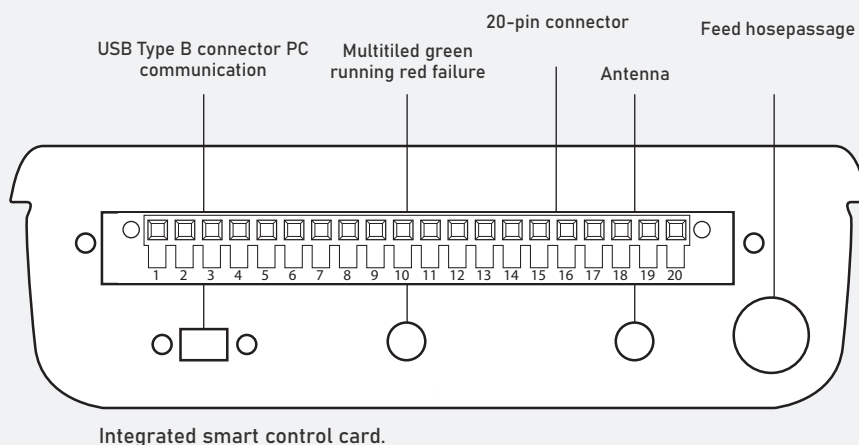
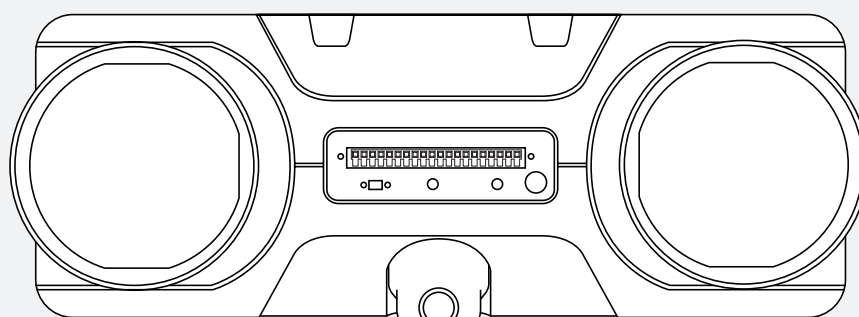

NUMBERING AND DESCRIPTION OF PIN CONNECTORS

CONNECTOR	DESCRIPTION	PLATE	CONNECTOR	DESCRIPTION	PLATE
PIN 1	Home automation input 10 v	X-26	PIN 11	Not used	
PIN 2	Home automation input 0V	X-26	PIN 12	Common selector 3V V1 230V	X-9
PIN 3	Home automation dry contact input	X-25	PIN 13	Selector 3V V2	X-9
PIN 4	Home automation dry contact input	X-25	PIN 14	Selector 3V V3	X-9
PIN 5	Forecast probe external Canadian well	Forecast	PIN 15	Post heating output 230 V	X-17
PIN 6	Forecast probe external Canadian well	Forecast	PIN 16	Post heating output Ground	X-17
PIN 7	Not used	X-16	PIN 17	Post heating output Neutral	X-17
PIN 8	Not used	X-16	PIN 18	Output 230 V Close Canadian Well Actuator	X-28
PIN 9	Not used	X-32	PIN 19	Output 230 V Open Canadian Well Actuator	X-28
PIN 10	Not used	X-32	PIN 20	Neutral Output Canadian Well Actuator	X-28

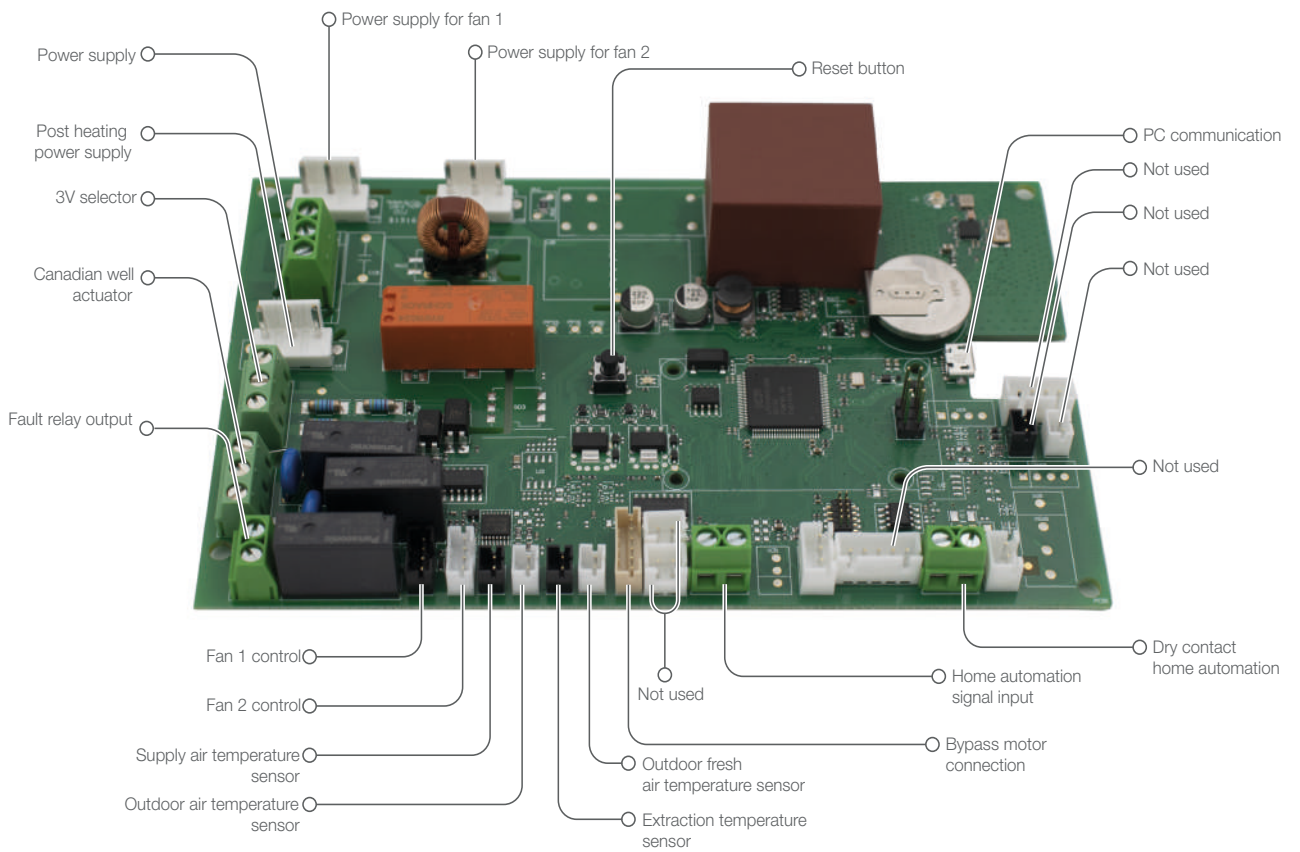
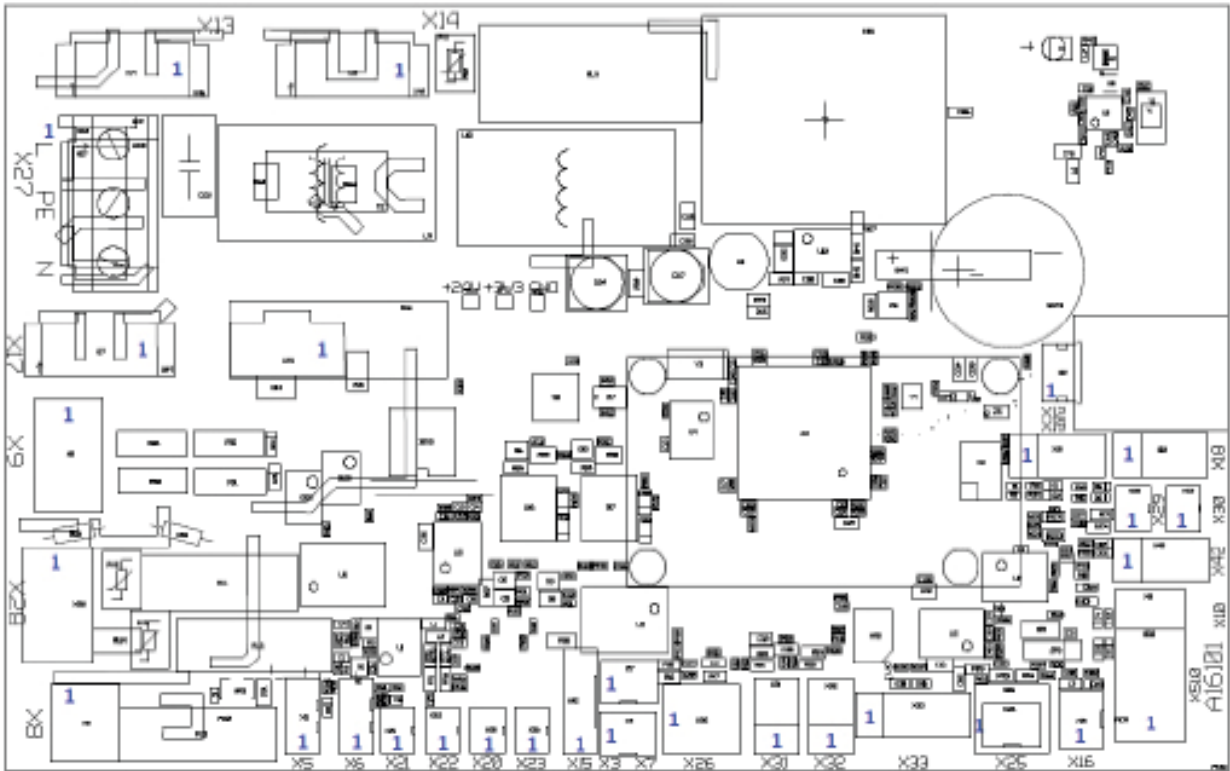

10 MONITOR YOUR HOME - PROBES / WIRELESS CONTROLS

take care of your health and that of your loved ones by monitoring the Air Quality in your home!

The Siber EVO unit can be equipped with various (optional) wireless accessories:

- Wireless CO₂ probe
- Wireless Humidity sensor (RH)
- Wireless smart Multicontrol
- Wireless 4-position push-button control

Siber EVO Probes/Control Command (optional)	
Wireless multicontrol	DFEVOCTRL
Wireless 4-position push-button control	DFPULS4B
Wireless CO ₂ probe	DFEVOCO2
Wireless Humidity sensor (RH)	DFEVOHR



The Siber Smart Wireless Multicontrol communicates via RF (radio frequency) with the ventilation unit and can choose from 5 different flow rate positions linked to the unit. It is a user and installation interface for monitoring and configuring the connected heat recovery unit. It has multiple functions connected to the Unit.



The Siber 4-Position Wireless Push Button Control communicates via RF (radio frequency) with the ventilation unit and can choose between 4 different positions linked to the unit. It has a dirty filter indicator.



The wireless Siber CO₂ probe monitors the CO₂ level of the air inside the house. It measures the CO₂ in the rooms of the house and sends its measurements via RF (radio frequency) to the Siber EVO Unit. The unit will be able to react and vary the appropriate ventilation flow rate to ensure the indoor air quality according to the information from the probe.



The wireless Siber HR (Relative Humidity) Probe controls the relative humidity of the indoor air in the house. It measures the indoor humidity in damp rooms and sends its measurements via RF (radio frequency) to the Siber EVO Unit. The unit will be able to react and vary the ventilation flow rate suitable for the indoor air quality according to the information from the probe.

11 SMART CONNECTIVITY

You can turn the dwelling into a smart home (optional) using various available gateways, as well as to connect the unit to your mobile device with the Siber EVO APP.

- MODBUS - RS485
- KNX - Evo Connect
- Ethernet bridge (specifies Siber EVO APP connection)

11.1 MODBUS - RS485

- » The Siber RS485 device (DFEVORFRS485) connects to the building management system (BMS) via cable, in Modbus language for both reading and writing data. Collects information from Siber EVO units and compatible wireless probes and controllers (DFPULS4B, DFEVOCTRL, DFEVOC02 and DFEVOHR) that are linked to this ventilation unit.



11.2 KNX - EVO CONNECT

- » The EVO CONNECT device (DFEVOCONNECT) is a modbus / knx converter. It needs to be connected by cable to the gateway (Modbus - RS485) to translate the information collected by the gateway (Modbus - RS485) and send it by cable to the BMS. Collects information from Siber EVO units and compatible wireless probes and controllers (DFPULS4B, DFEVOCTRL, DFEVOC02 and DFEVOHR) that are linked to this ventilation unit.
- » The Evo Connect requires a 24 V power supply for its proper operation.

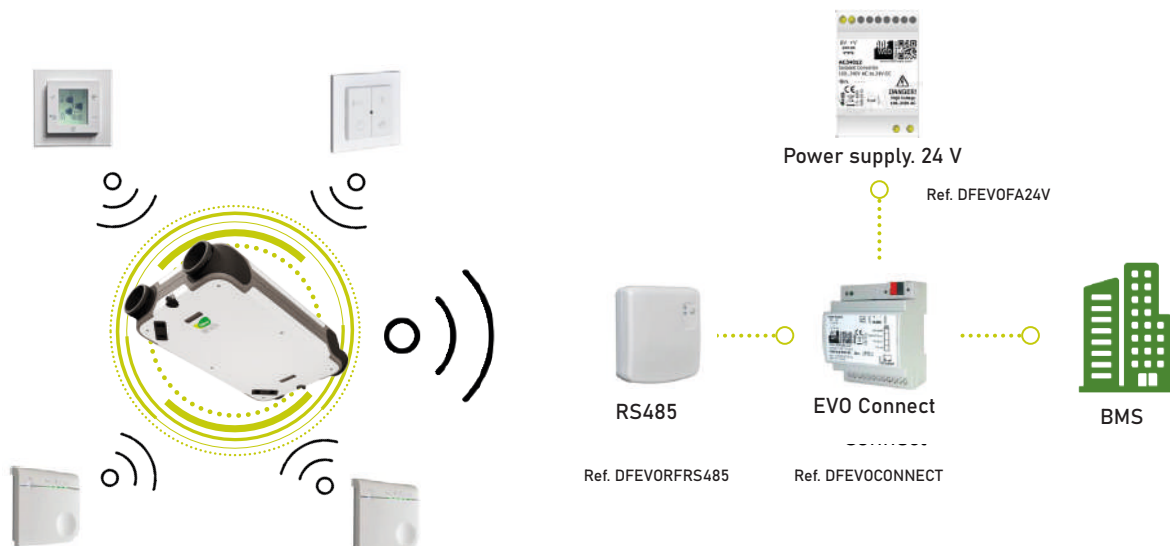

11.3 BRIDGE ETHERNET - SIBER EVO APP

Thanks to the smart control system, online monitoring of the most important elements is achieved, making it possible to control and monitor the indoor air quality of the home through the Siber EVO APP.

- Control and regulation of the unit's speeds.
 - Monitoring of CO₂ and relative humidity in the home.
- » The Siber EVO unit collects information from the various compatible wireless probes and controllers (DFPULS4B, DFEVOCTRL, DFEVOC02 and DFEVOHR) via radio frequency.
- » The information is sent to the Ethernet gateway (Ethernet Bridge - DFEVORFETH - DFEVORFETH) DFEVORFETH, whose device must be connected by cable to the home's internet connection modem, transferring the collected data to the "cloud" to provide access and monitoring of the data via the Siber EVO APP.



12. MAINTENANCE

12.1 FILTER MAINTENANCE (FOR THE USER)

Filters should be checked every three months. Filters should be cleaned every six months and replaced at least once a year.

! **Note:**
The equipment must never be operated without filters

1 Remove the filter cover.

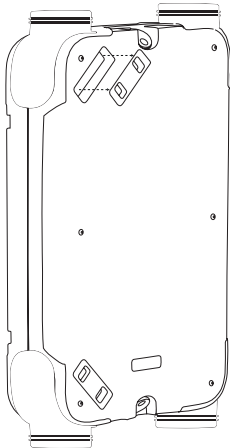

2 Pull the filter outwards.

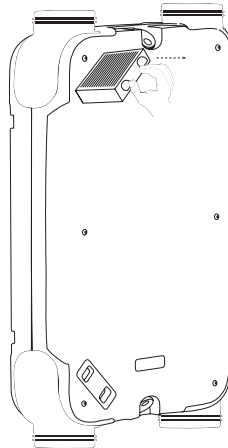

3 Vacuum the filter to remove the dirt

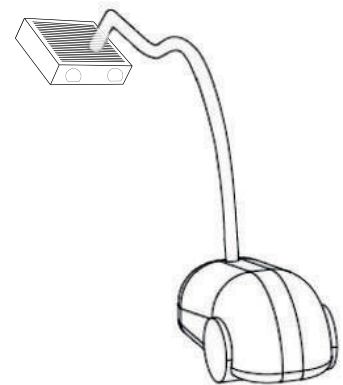

4 Place the new filter in the slot and push it in.

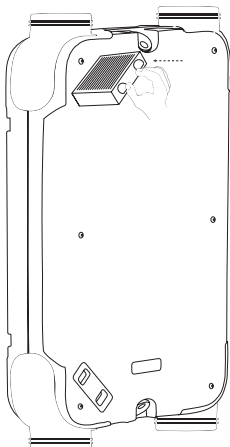

5 Replace the filter covers

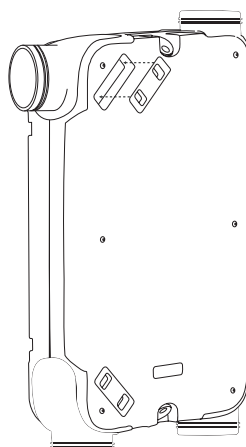

12.2 MAINTENANCE OF THE HEAT EXCHANGE (FOR THE INSTALLER)

1 Remove the filter cover.

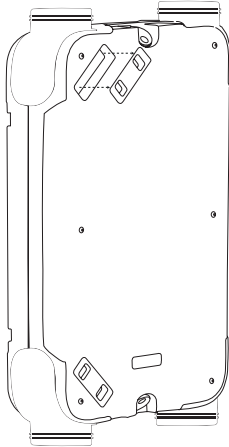

2 Pull the filter outwards.

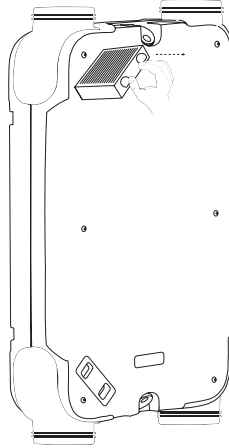

3 Unscrew the outer cover

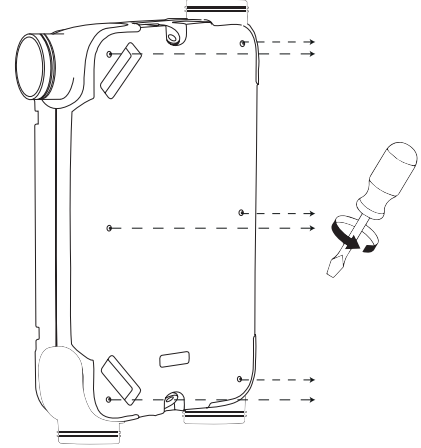

4 Remove the outer cover and the front polypropylene of the Unit, leaving the interior exposed

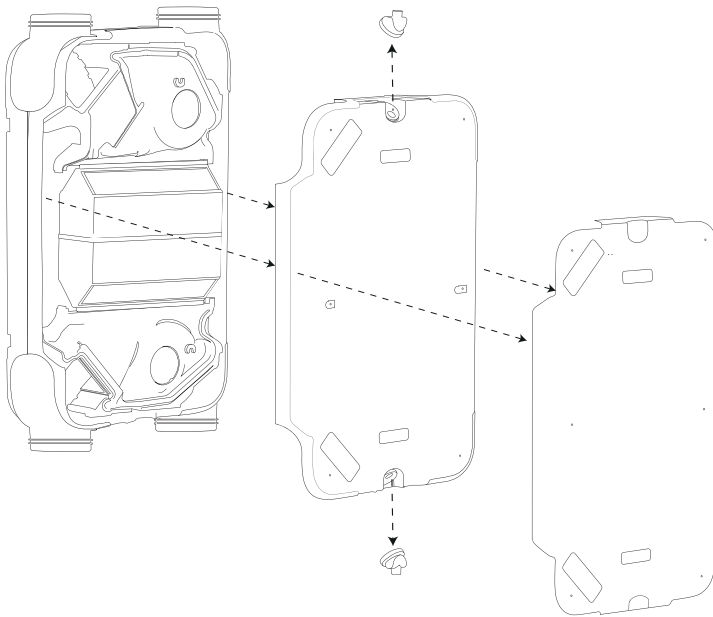

5 Unscrew and remove left support bracket

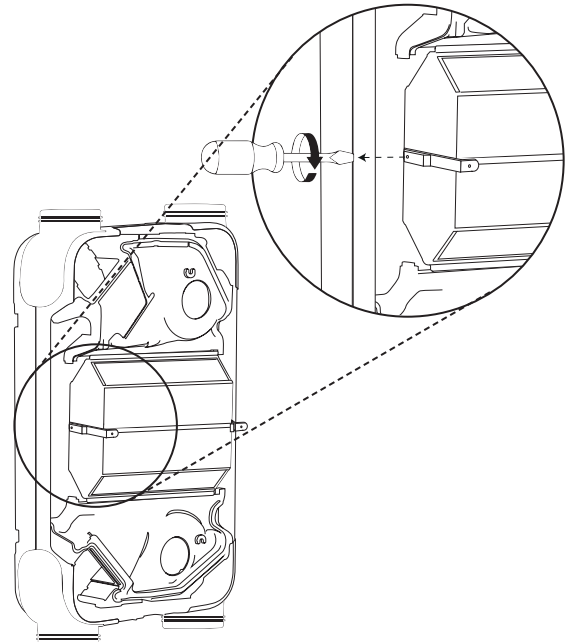

6 Separate the retaining tabs to remove the heat exchanger

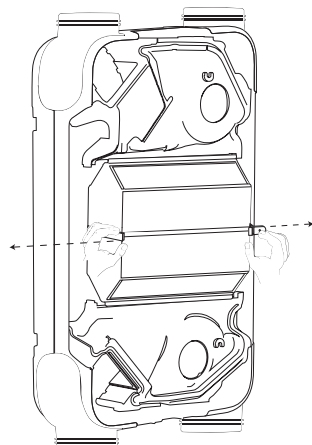

7 Remove the heat exchanger

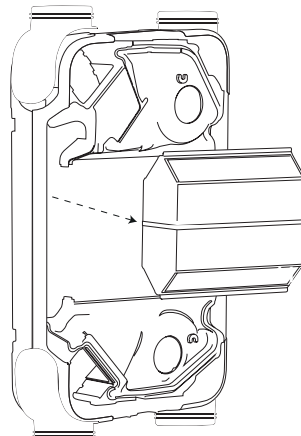

8 Clean the heat exchanger with water

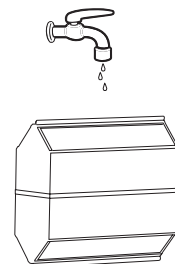

! Note:

Carefully remove the heat exchanger, a small amount of condensation water may still remain in the heat exchanger.

9 Put the heat exchanger back in place

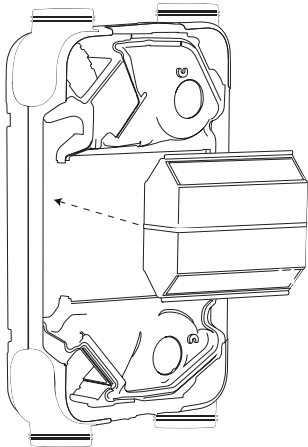

10 Insert the support bracket and screw it back on

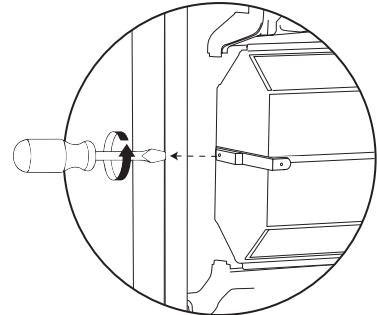

11 Fit the outer and inner cover of the Unit.

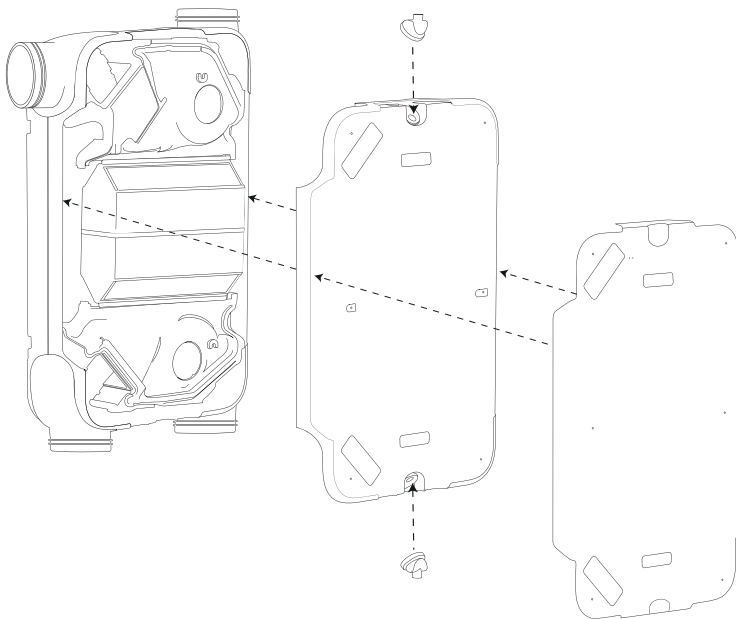

12 Screw on the outer cover

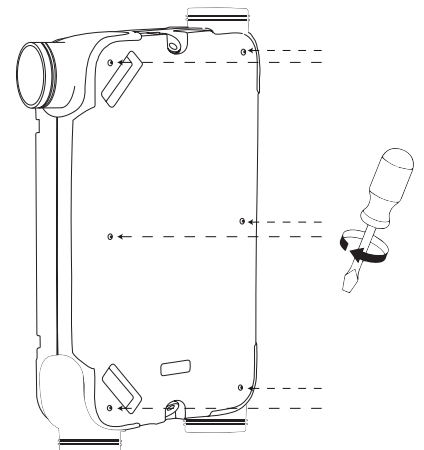

13 Replace the filters

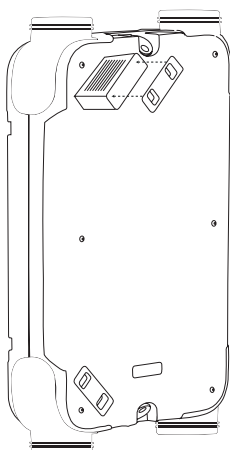

14 Replace the filter covers

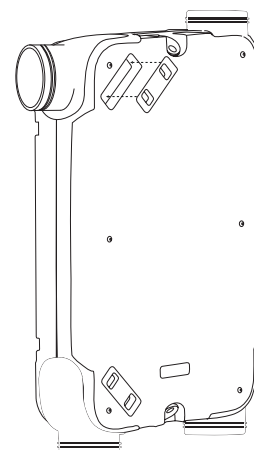

12.3 EXPLODED VIEW AND DESCRIPTION

No,	Article description SIBER EVO 1/2	
1	Orientable nozzles 160 Ø	4 units
2	Front cover	1 piece
3	Front Polypropylene	1 piece
4	By-Pass Valve	1 piece
5	By-Pass valve motor	1 piece
6	Energy-saving fan	2 units
7	High-performance heat exchanger	1 piece
8	Fastening tabs	2 units
9	Swivelling condensate drain	2 units
10	High performance filter	2 units
11	Filter Cover	2 units
12	Temperature probe	4 units
13	Connection plate	1 piece
14	Silentblock	4 units
15	Electronic connection board	1 piece
16	Preheater 600W	1 piece

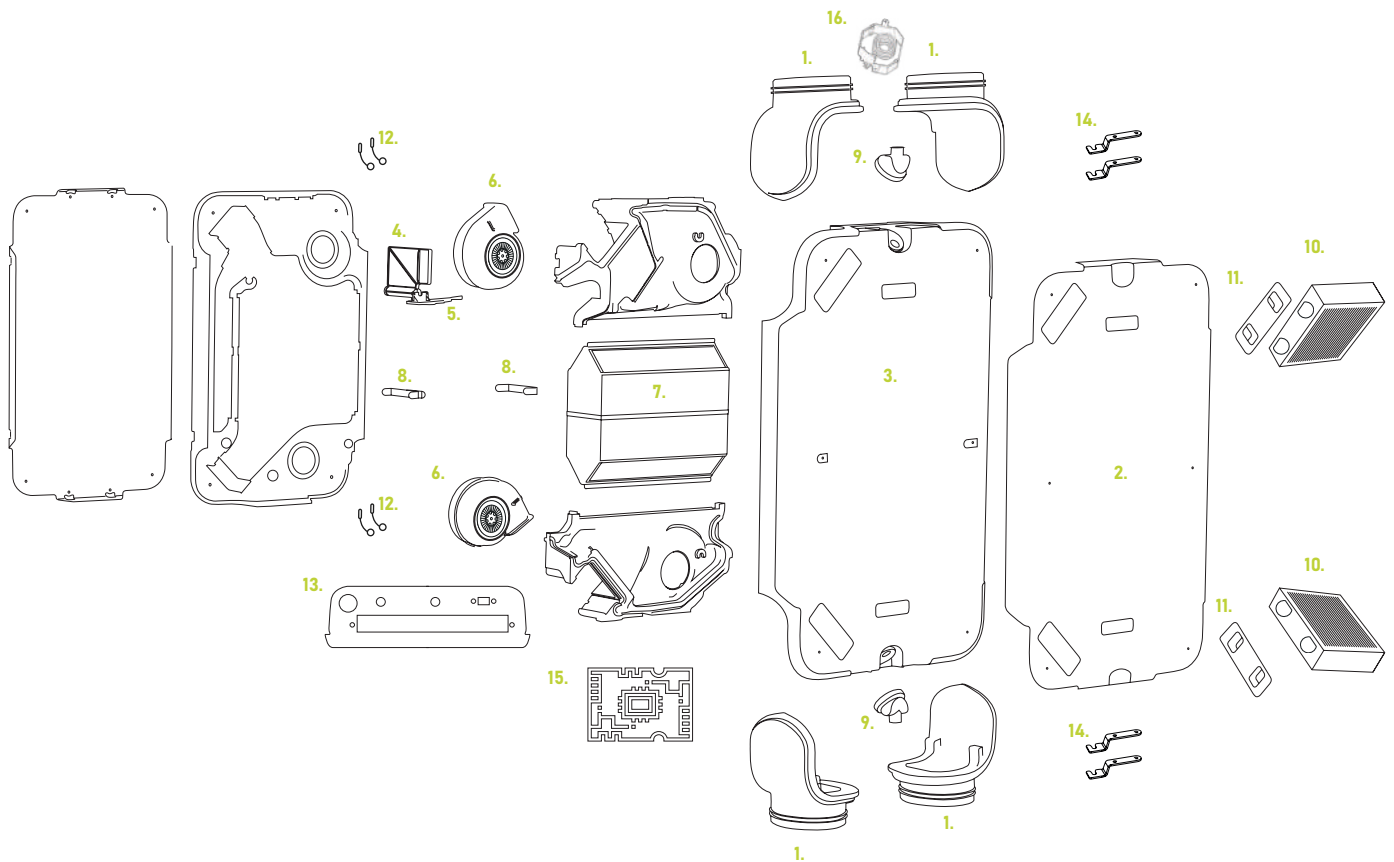

All **Siber** products are carefully tested and are covered by a warranty for a period of 36 months from the date of purchase, in accordance with current legislation.

These rights, as provided for in the above-mentioned legislation, may only be asserted with respect to the seller himself.

Within this period, **Siberzone S.L.U** .will repair and/or replace, at its own account and expense, any components which, in its unquestionable judgement, are recognised to be malfunctioning.

The following cases are excluded from the guarantee and invalidate its validity:

- Installation of the appliance by non-professionally trained personnel (applies only to appliances not equipped with the manufacturer's plug);
- Non-compliance with the suggestions for use, installation, and maintenance indicated in the corresponding instruction manual;
- Breakage due to misuse and neglect;
- Breakage caused by transport;
- Wrong connection to the power supply.
- Power supply at a voltage different from that indicated on the device.
- Repairs or manipulations carried out by unauthorised personnel;
- Interventions due to defects or falsified verifications.
- Missing guarantee certificate and/or guarantee certificate not filled in;
- Removal or alteration of the label and stamp proving the date of manufacture.

In any case, the product returned for repair or replacement must be returned to the place where it was purchased, together with this certificate duly completed and with the corresponding tax document proving the date of installation.

This warranty never extends to the obligation to repair damages of any kind or nature suffered by persons and/or things.

<p>Siber Zone, SLU. Apdo. de Correos nº 9 - C/Can Macia nº 2 08520 Las Franquesas del Vallés (Barcelona) Tel: 902 02 72 14 Fax: 902 02 72 16 E-mail siber@siberzone.es</p>	<p style="text-align: center;">CERTIFICATE Central VMC DF Siber:</p> <p>Address of the work: _____ _____ Apartment/Dwelling: _____ Municipality: _____ Province: _____</p>
--	--

In accordance with the LOPD "Organic Law for the Protection of Personal Data", we inform you that your signature on this contract will be considered as acceptance to the processing of the company's data as dictated by the indicated law. We also inform you that the provision of such data is necessary to fulfil the obligations referred to in this guarantee.

Distributor/Manufacturer stamp:

Installer Seal:

SIBERZONE, SLU
 C/ Can Macia, nº 2
 Telf. 902 02 72 14 Int. +34 93 78616261
 Fax: 902 02 72 16 Int. +34 93 7814108
 08520 LAS FRANQUESAS DEL VALLES
 Barcelona España

Delivery date: _____

Sealed at: _____

Commissioning date: _____

Date: _____



Tel: 902 02 72 14 / Int. 00 34 938 813 18
 Fax: 902 02 72 16 / Int. 00 34 938 813 08
 siber@siberzone.e
 www.siberzone.e

Sustainable ventilation and air handling systems



Tel. 902 02 72 14
Int. 00 34 938 616 261
Fax. 902 02 72 16
Int. 00 34 937 814 108

siber@siberzone.es
www.siberzone.es

Siber Zone, S.L.U.

HEADQUARTERS
Central Offices

Logistics Centre - Showroom
Factory - Training Centre

Apdo. de Correos 9
C/ Can Macia n. 2
08520 Les Franqueses del Vallès
Barcelona-España

LOGISTICS AND TRAINING CENTRE

Offices - Logistics Centre
Showroom - Training Centre

C/ Jacinto Benavente, n. 5 nave 3
28850 Torrejón de Ardoz
Madrid-Spain

INNOVATION CENTRE

Offices - Logistics Centre
Showroom - Training Centre

C/ De Portugal, 18
08520 Les Franqueses del Vallès
Barcelona-España

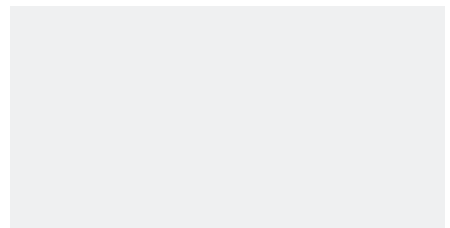

No part of the contents of this publication may be reproduced in any form without the express permission of the owner. Siber Zone, S.L.U. reserves the right to make any technical modification to the equipment and elements without prior notice.