

THE EVOLUTION OF UV DISINFECTION



*shown with
optional
mounting
bracket

OEM MODULE AND INTEGRATED LED SYSTEM

As the development of UVC LED technology continues its rapid growth, LUMINOR has expanded on the proven efficacy of UV germicidal irradiation, and coupled it with high-tech UVC LED technology, to produce an energy efficient, environmentally friendly technology of the future. These compact UVC LED modules provide 99.99% pathogen reduction and have a global reach with a myriad of applications ranging from residential water treatment, water dispensers, appliances, food service, RV, marine, medical, disaster relief and many, many more!

Why LED?

- Compact footprint, high power density UVC LEDs combined with integral solid state control architecture allow for a much smaller installation footprint than traditional UV systems
- UVC LEDs are “instant-on” devices, requiring no warm-up time to achieve disinfection. This allows for eco-friendly operation in response to water flow
- UVC LEDs have an extremely long service life resulting in reductions in lamp replacement and labour expenses
- Unlike traditional UV lamps containing mercury, UVC LEDs are free of hazardous materials, which eliminates the risk of a mercury spill due to a lamp breakage
- Eco friendly, extremely low power consumption and no potentially dangerous chemicals used in their construction
- Unlimited cycling, UVC LED is not impacted by on/off cycles
- Temperature independent constant UVC output regardless of water temperature. Plus, UVC LEDs do not transfer heat from the light emitting surface, thus limiting lamp fouling
- Wavelength selectivity, LUMINOR can custom tailor the wavelength of the LED module for customized UVC applications



GUV-4S



GUV-5S



Everything is included in this compact, all-in-one module

This fully integrated LED based UV disinfection system is available with either the simple multi-state status indicator (GUV-4S), or the full colour screen interface (GUV-5S & includes IEP port for expansion modules).

This system is packaged with a 12 volt power supply and there is no need for a lamp change, as in traditional UV systems. The UVC LED's only turn "on" when needed based on an integral flow switch, and last for 5,000 hours of "on" mode operation.

The system incorporates integrated, real-time I/O monitoring for:

Temperature

- Prevents overheating of LED's
- Alarm alerts of over temperature conditions

LED Status

- Always know when UVC LED is on or off
- Alarm is signaled in event that the UVC LED fails

Sample Screens Available on GUV-5S Controller

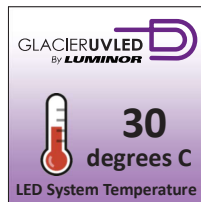

GUV-4S & 5S Dimensions

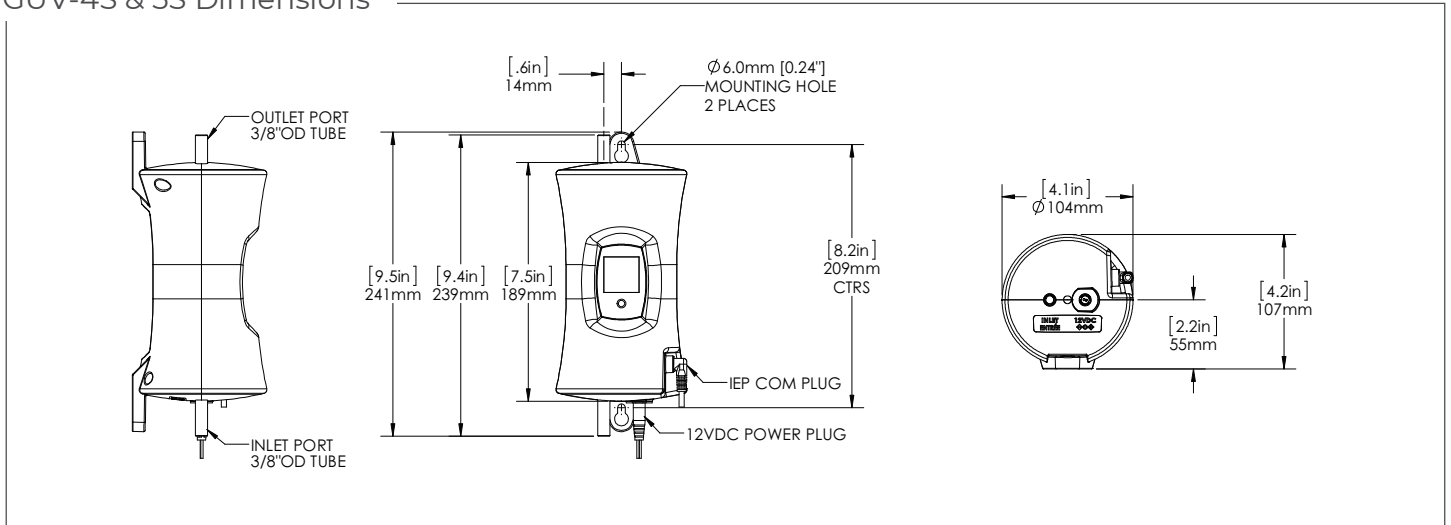

GLACIER UVC LED System Specifications

MODEL	GUV-2	GUV-5	GUV-4S	GUV-5S
Flow Rate @ (10 mJ/cm ² at 95% UVT)	0.7 GPM 2.7 lpm	1.5 GPM 5.6 lpm	1.5 GPM 5.6 lpm	1.5 GPM 5.6 lpm
Flow Rate @ (16 mJ/cm ² at 95% UVT)	0.4 GPM 1.5 lpm	1.3 GPM 4.9 lpm	1.3 GPM 4.9 lpm	1.3 GPM 4.9 lpm
Flow Rate @ (30 mJ/cm ² at 95% UVT)	0.2 GPM 0.6 lpm	0.6 GPM 2.4 lpm	0.6 GPM 2.4 lpm	0.6 GPM 2.4 lpm
Flow Rate @ (40 mJ/cm ² at 95% UVT)	0.1 GPM 0.4 lpm	0.4 GPM 1.3 lpm	0.4 GPM 1.3 lpm	0.4 GPM 1.3 lpm
UVT (%)	Recommended above 90%			
Headloss at Max Flow	41 mBar (0.6 psi)	166 mBar (2.4 psi)	166 mBar (2.4 psi)	
Max Pressure	6.9 bar (100psi)			
Max Ambient Temperature	50° C (122° F)			
Operating Water Temperature	0-45° C (32-113° F)			
Water Connections	3/8" OD Tube (fits John Guest® style quick connect fittings)			
Input Voltage	12VDC			
Input Power	8W	14W	15W	16W
Electrical Connection	4-core, 26 AWG, 6" length		Standard 12VDC barrel connector, 2.1 x 5.5 mm	
UV Intensity Monitoring	NA	Coming soon	NA	Coming soon
LED Status Monitoring	YES			
LED Life Monitoring	YES			
LED Life	5,000 hours			
Solenoid Output	NA	NA	NA	YES (optional module (MOD-SOL) sold separately)
Dry Contacts (solenoid ready)	NA	NA	NA	YES (optional module (MOD-RAM) sold separately)
Sherpa	NA	NA	NA	YES (optional module (MOD-SHERPA) sold separately)
IoT	NA	NA	NA	YES (optional module (MOD-APP) sold separately)
Display	NA	NA	Dual colour LED	Full customizable colour screen
Overall Dimensions (with mounting brackets)	119mm x 64mm x 76mm (4.7in x 2.5in x 3.0in)	133mm x 80mm x 93mm (5.2in x 3.2in x 3.7in)	241mm x 104mm x 107mm (9.5in x 4.1in x 4.2in)	
Shipping Weight	160 g (6 oz)	310 g (11 oz)	400 g (14 oz)	

Specifications subject to change without notice.



Third party microbiological testing in accordance with the US EPA drinking water guidelines



System Tested and Certified by WQA against NSF/ANSI-61 for material safety only. Certified to NSF/ANSI-372 for lead free compliance.



LUMINOR Environmental Inc.

80 Southgate Drive, Unit 4
Guelph, Ontario, CANADA N1G 4P5
P: (519) 837-
TF: (855) 837-3801
F: (519) 837-3808
E: info@luminoruv.com
www.luminoruv.com

Manufacturer's Warranty

GLACIER UV LED modules are covered by a One (1) year Limited Warranty
See website for LUMINOR's complete warranty document including conditions and exclusions.



LuminorUV



LuminorUV