



EVO



# Care about you & the others

The sustainable **EVO**lution in:

- Comfort
- Air purification
- Energy efficiency



- 01. HEALTH & COMFORT
- 02. HIGH PERFORMANCES
- 03. DESIGN & INNOVATION
- 04. VERSATILITY
- 05. SUSTAINABILITY
- 06. IoT
- 07. TECHNICAL FEATURES

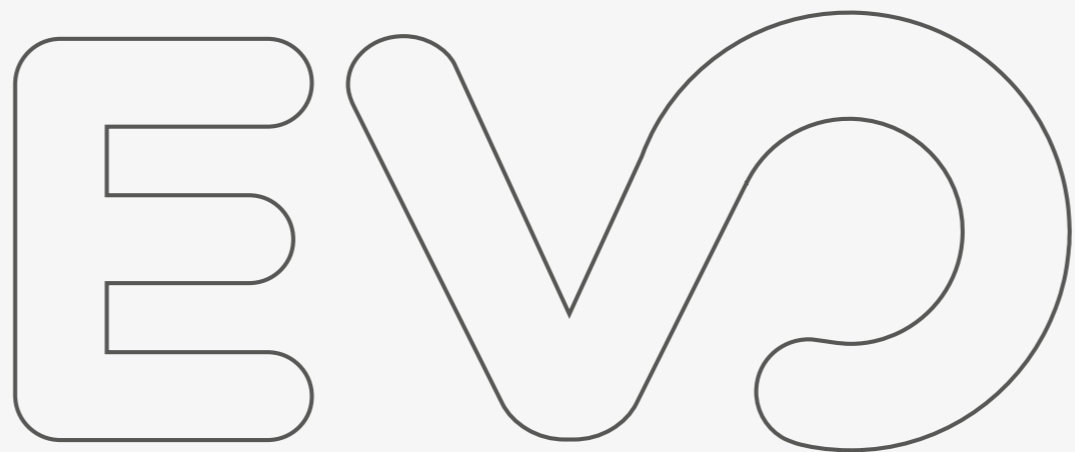

# 01 THE EVOLUTION IN HEALTH & COMFORT



## Silent

A high performance unit which ensure accoustic comfort thanks to a constant airflow

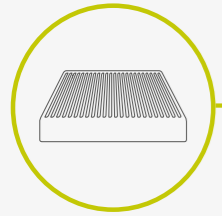

## Large choice of customized filters

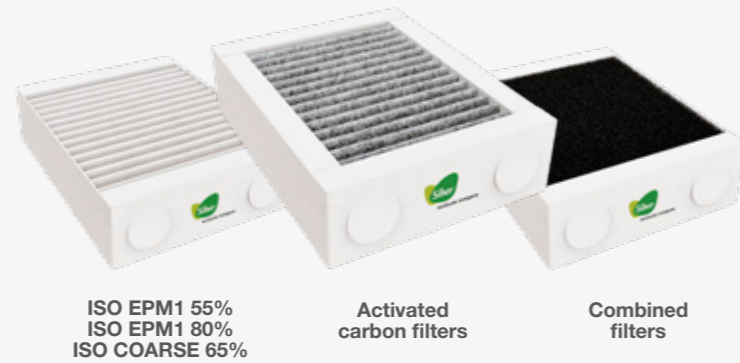

Our filters assure the quality of the air you breath

### The nose filters particles from 9 µm



- 100 µm are caught in the nose
- 10 µm are caught in the throat
- 2,5 µm cover the lungs
- 1 µm enter in the blood flow

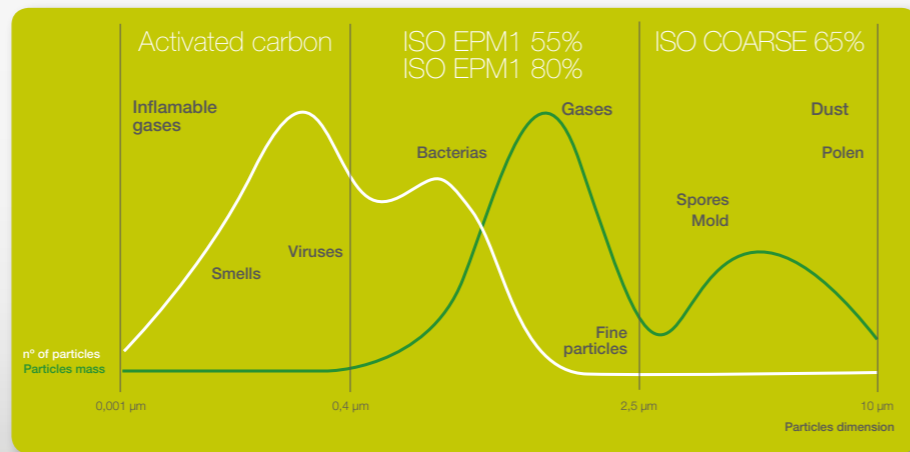

A healthy air, a better life

# 02 HIGH PERFORMANCES

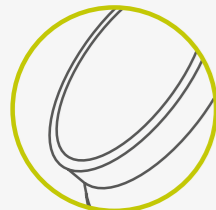
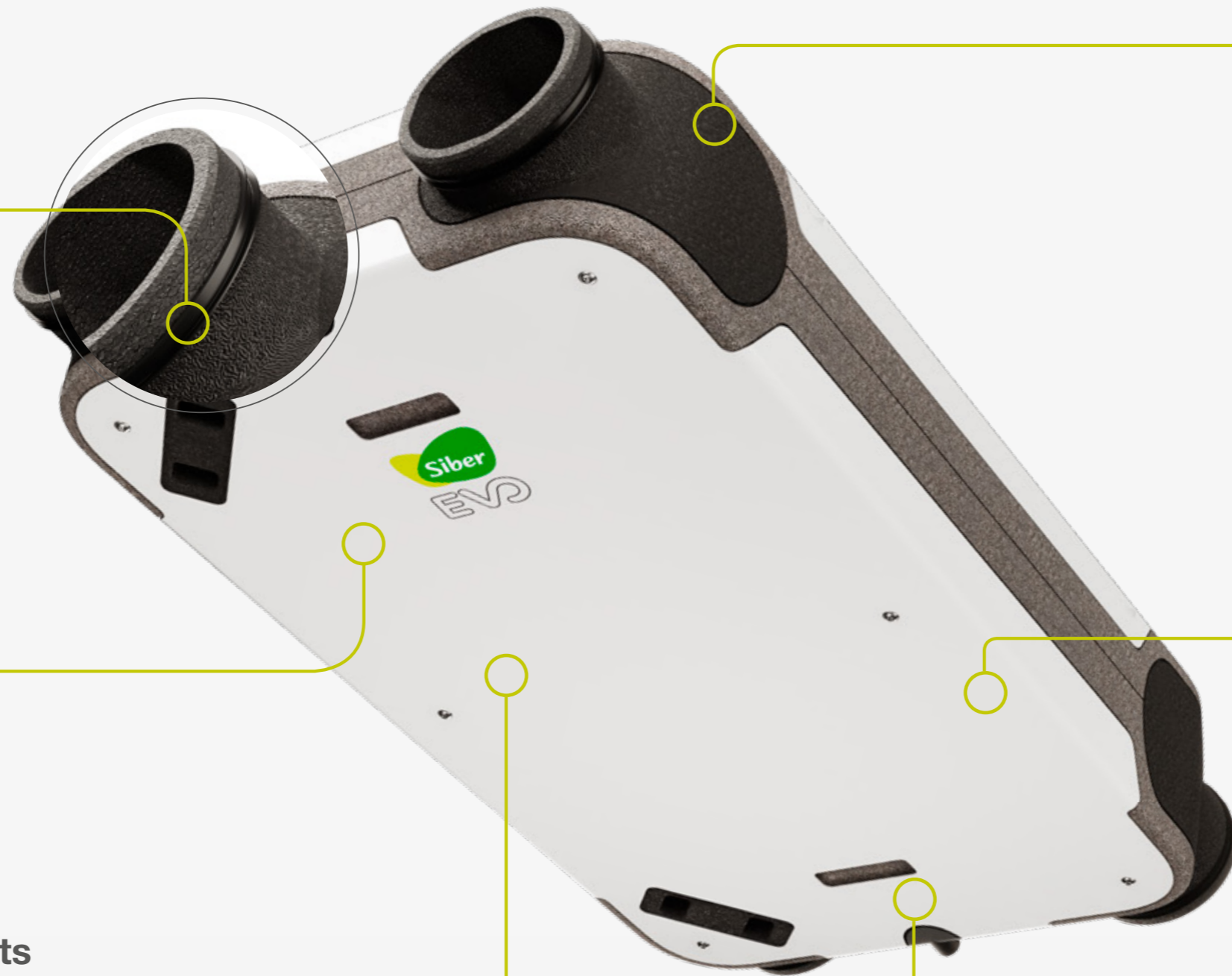

## Best sealing

The connections are designed to ensure the maximum tightness.

That is thanks to a double symmetrical joint that allows a perfect sealing between the unit and the duct.



## Low consumption

High performance motors paired with an exclusive technology, allowing a reduction in consumption.



## Reaching summits in energy efficiency

The unit is designed to allow cross flows within it. That is thanks to a high performance, counterflow, heat recovery exchanger

up to **95%**

## Less pressure, better airflow



Thanks to its aerodynamic design, EVO gets a better airflow without an increase of the inside pressure.



## Constant airflow

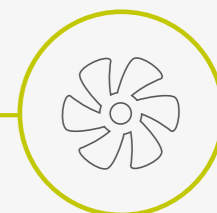

Constant airflow technology, based on device current centrifugal fans and forward oriented blades that are working permanently.

Thanks to this, EVO ensure constant airflow, acoustical comfort, lower consumptions, easy maintenance and a better air quality.

## Certificates



EVO possesses the most prestigious quality certificates



# 03 DESIGN & INNOVATION

0%

## Fully horizontal instalation

Thanks to its interior design, it is not necessary to inclinate EVO for the condensation drain.



## No need of the 2% inclination

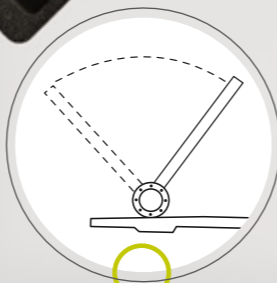

## Orientable connection

EVO is the first HRV unit with modularity. Easy and fast configuration.

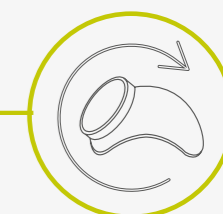

## Rotating condensation drain

The condensation drains can rotate 180° so they adapt to any kind of installation parameters.



## Ultra compact & minimalistic design

EVO is the most compact unit in the market with only 21 centimeters height.

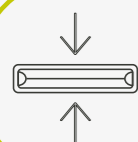

## Intelligent & Automatic By-Pass

The By-Pass works perfectly on both summer and winter periods allowing to get the perfect temperature inside the house without using the heat recovery exchanger.

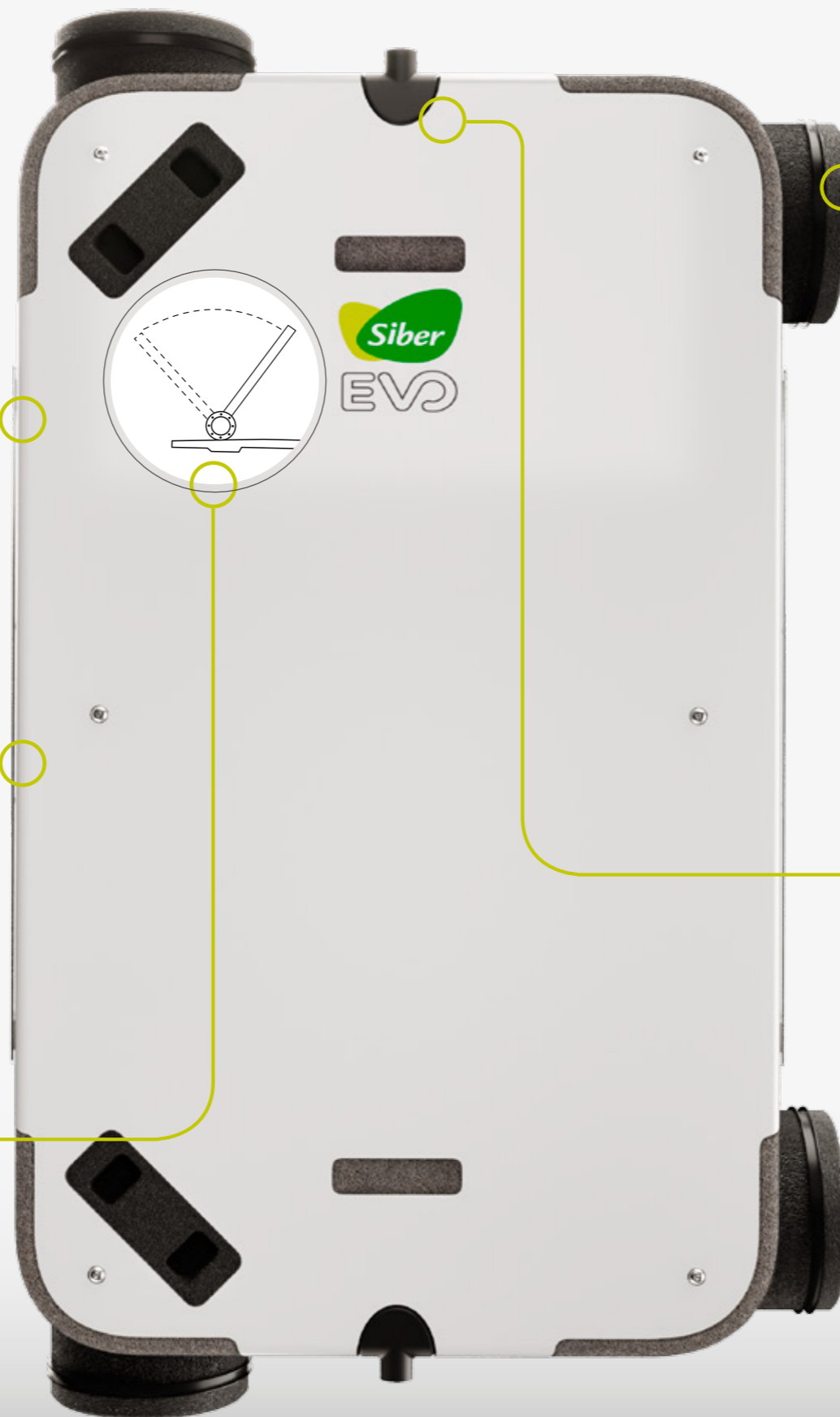

# 04 VERSATILITY

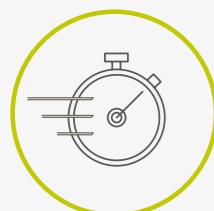

## Easy & fast installation

Even though EVO's installation is intuitive, we made sure even its packaging shows how to install it.

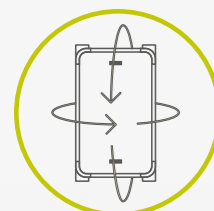
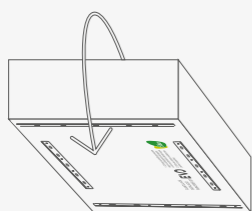

## Polyvalent (Left/Right)

EVO can be configured left/right without any complication and during the installation.

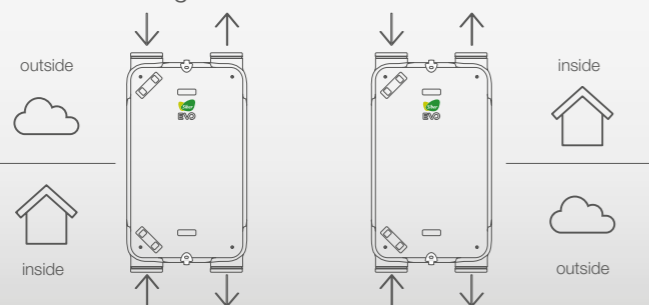

Right version  
(factory version)

Left version  
(performed "mirror mode")

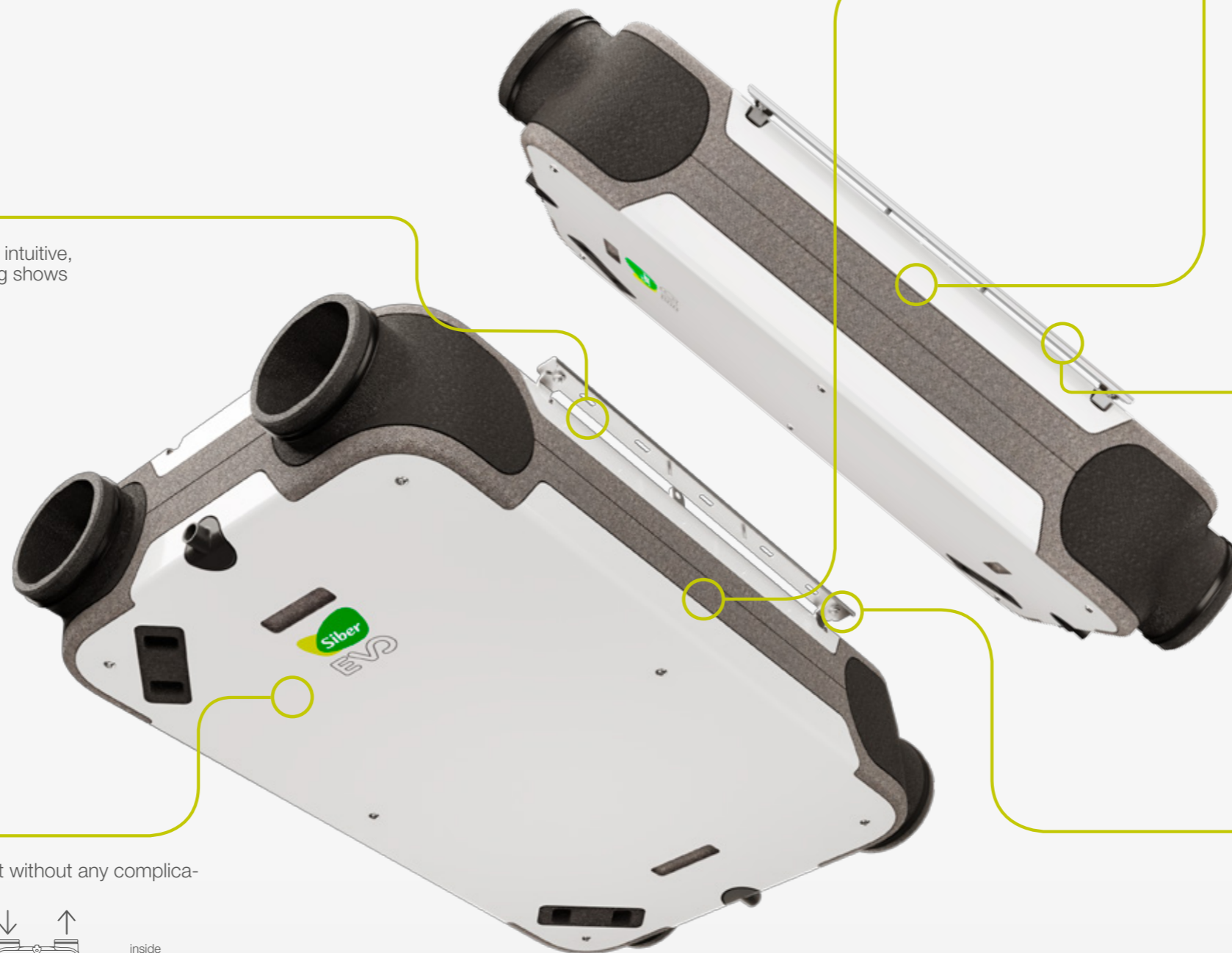

## Vertical/Horizontal installation

It has 2 supports which allow them an easy installation both on the wall or on the ceiling



## Orientalive guides

Possibility to install various guides in both laterals thanks to silentblock hooks.

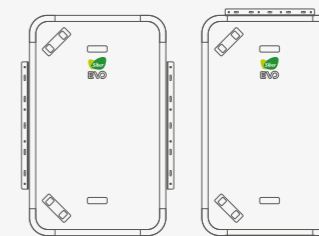

## Silentblock hooks

Simple fixation thanks to 4 antivibration hooks eliminating any kind of trembling.

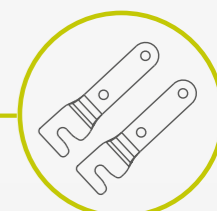
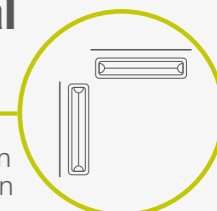
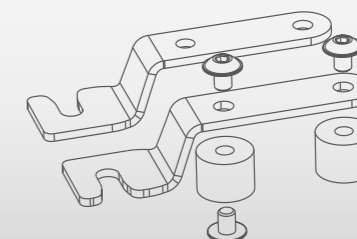

# 05 SUSTAINABILITY

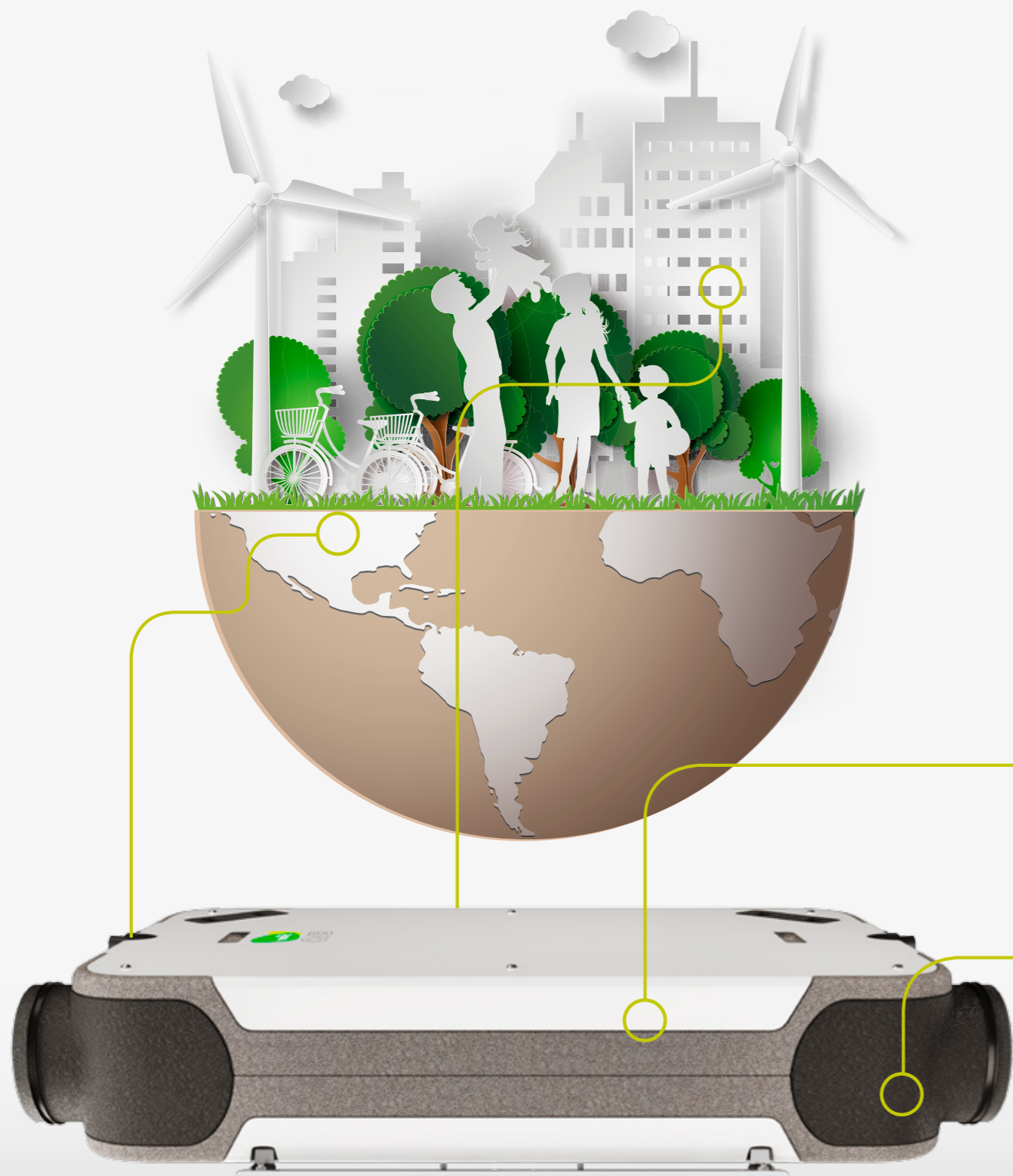

**We evolve and fight for a sustainable environment.**

## Sustainability

EVO is made of expanded polypropylene and galvanized steel. It makes it totally recyclable, reducing the consumption of resources and so Earth's degradation.

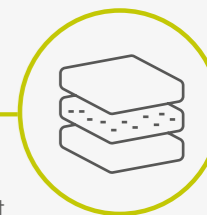

**99,9% recyclable**

## No carbon footprint

Lower volume of inflammable gases. It helps in the management of the climate change.



06

Convert your nest in a Smart Home with Siber.

Upgrade your home automation to improve the quality of the air.



Connectivity through:

**KNX**  
**Modbus**

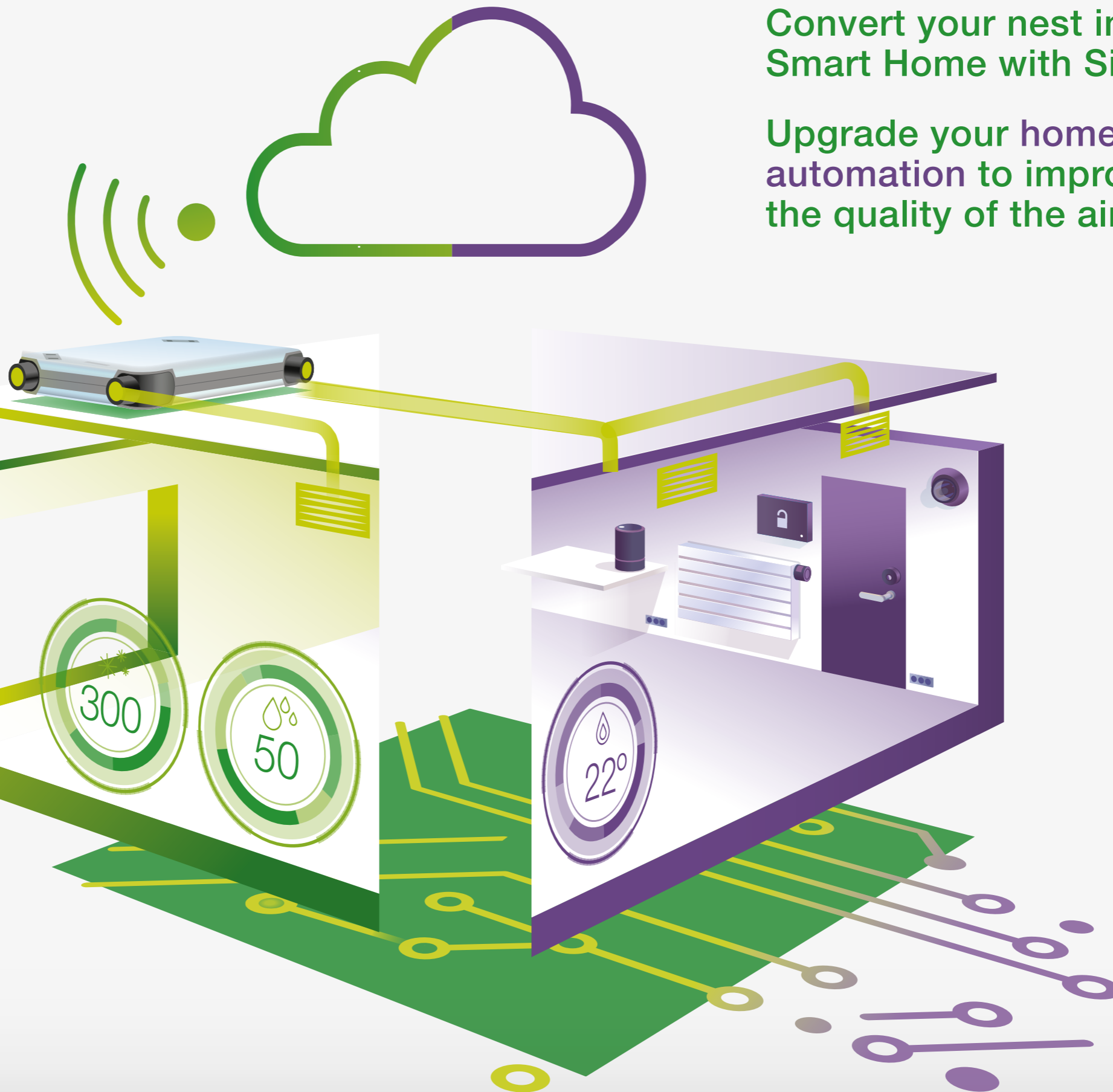
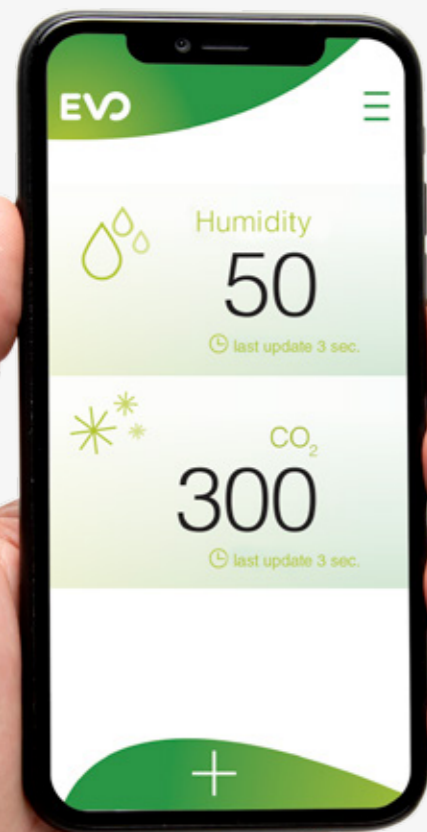

The quality of the air you breath in the palm of your hand.



# 07 TECHNICAL FEATURES



## Dimensions

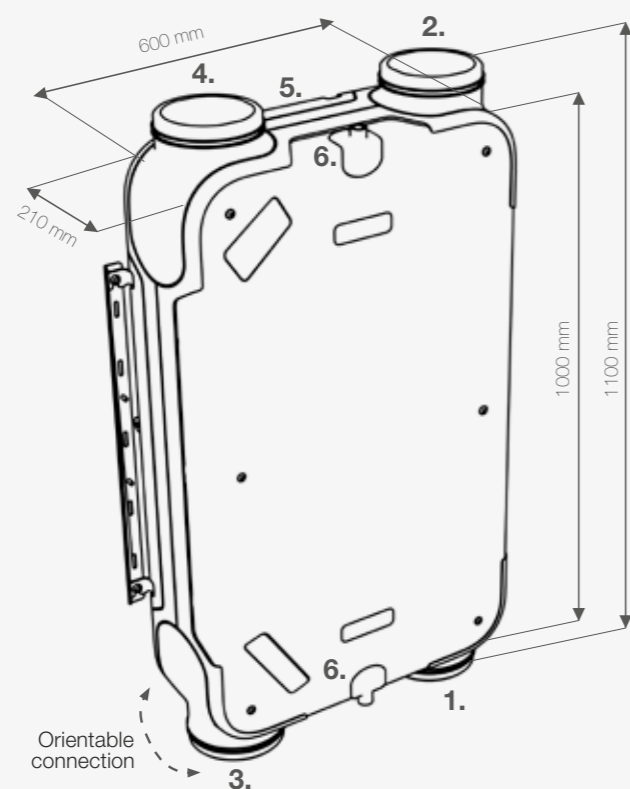

Airflow right version (factory version)

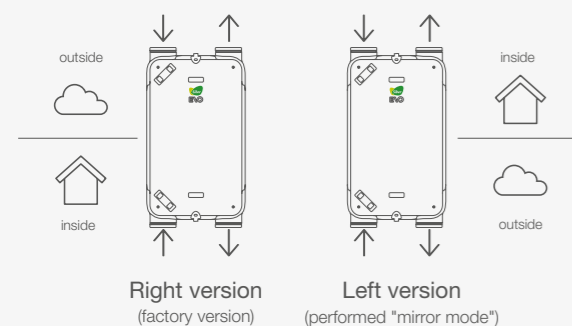

1. Insufflation of new air to the home
2. Extraction of foul air
3. Extraction of foul air from the inside of the home
4. New air's intake from outside
5. Electrical connection
6. Condensation drain connection\*

\*It can only have one condensation drain, the other one has to remain closed with a plug.

## SIBER DF EVO 1

SIBER® DF EVO 1					
Supply voltage	230V/ 50 Hz				
Firewall protection	IP 40				
Dimensions (l x h x p)	1000 x 600 x 210 mm				
Connection's diameter	Ø 160				
Condensation drain diameter	1/2"				
Weight	24 Kg				
Filter's type	Coarse 65% (G4)				
Fan position (standard)					Boost mode
Wireless intelligent multi-controller (optional)	0	1	2	3	Max
Airflow (m³/h)	30	75	100	140	150

Acoustic level SIBER® DF EVO 1							
Airflow (m³/h)		50	75	100	150		
Acoustic level Lw (A)	Static pressure (Pa)	25	50	50	100	100	150
	Box irradiation (dB(A))	24	34	38	44	45	49
	Extraction duct (dB(A))	28	30	39	42	46	47
	Insufflation duct (dB(A))	42	50	53	56	61	64

### CHARACTERISTIC CURVE

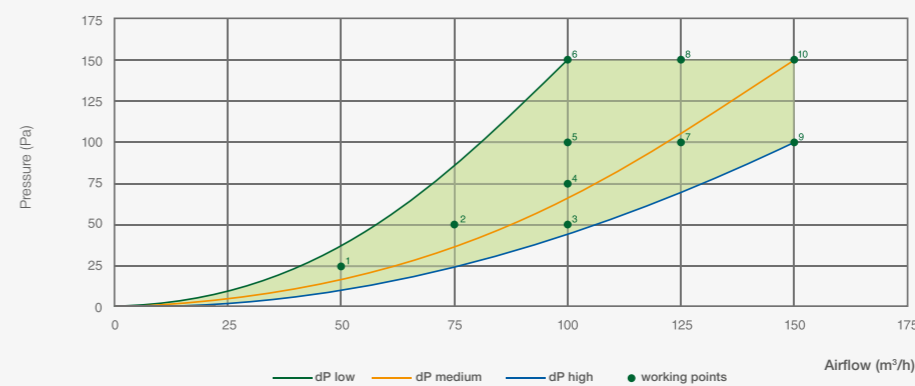

Working points	AIRFLOW (m³/h)	PRESSURE (Pa)	POWER (W)	SFP (W/l/s)
1	50	25	9.24	0.67
2	75	50	15.37	0.74
3	100	50	20.55	0.74
4	100	75	24.52	0.88
5	100	100	28.87	1.04
6	100	150	37.62	1.35
7	125	100	37.13	1.07
8	125	150	46.07	1.33
9	150	100	48.14	1.16
10	150	150	58.25	1.40



## SIBER DF EVO 1 Enthalpic Mode

SIBER® DF EVO 1 Enthalpic Mode					
Supply voltage	230V/ 50 Hz				
Firewall protection	IP 40				
Dimensions (l x h x p)	1000 x 600 x 210 mm				
Connection's diameter	Ø 160				
Condensation drain diameter	1/2"				
Weight	24 Kg				
Filter's type	Coarse 65% (G4)				
Fan position (standard)					Boost mode
Wireless intelligent multi-controller (optional)	0	1	2	3	Max
Airflow (m³/h)	30	75	100	140	150

Acoustic level SIBER® DF EVO 1 Enthalpic Mode							
Airflow (m³/h)		50	75	100	150		
Acoustic level Lw (A)	Static pressure (Pa)	25	50	50	100	100	150
	Box irradiation (db(A))	24	34	38	44	45	49
	Extraction duct (dB(A))	28	30	39	42	46	47
	Insulation duct (dB(A))	42	50	53	56	61	64

### CHARACTERISTIC CURVE

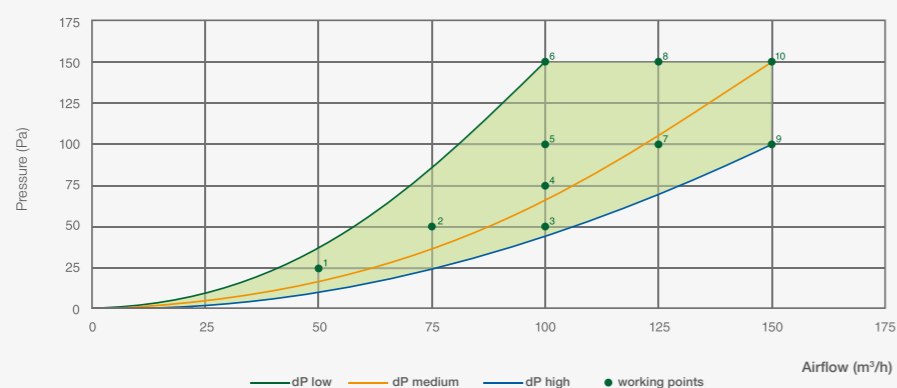

Working points	AIRFLOW (m³/h)	PRESSURE (Pa)	POWER (W)	SFP (W/l/s)
1	50	25	9.24	0.67
2	75	50	15.37	0.74
3	100	50	20.55	0.74
4	100	75	24.52	0.88
5	100	100	28.87	1.04
6	100	150	37.62	1.35
7	125	100	37.13	1.07
8	125	150	46.07	1.33
9	150	100	48.14	1.16
10	150	150	58.25	1.40

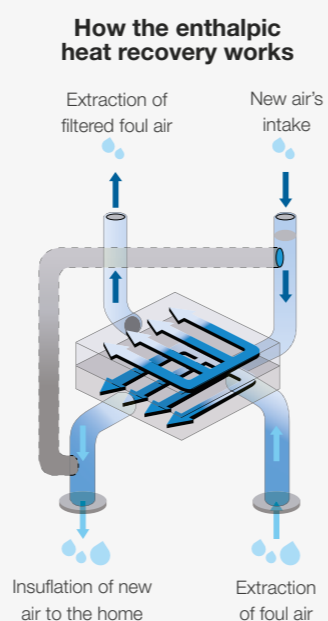

## SIBER DF EVO 2

SIBER® DF EVO 2					
Supply voltage	230V/ 50 Hz				
Firewall protection	IP 40				
Dimensions (l x h x p)	1000 x 600 x 210 mm				
Connection's diameter	Ø 160				
Condensation drain diameter	1/2"				
Weight	24 Kg				
Filter's type	Coarse 65% (G4)				
Fan position (standard)					Boost mode
Wireless intelligent multi-controller (optional)	0	1	2	3	Max
Airflow (m³/h)	30	75	100	150	200

Acoustic level SIBER® DF EVO 2							
Airflow (m³/h)		75	125	150		200	
Acoustic level Lw (A)	Static pressure (Pa)	25	50	50	100	150	200
	Box irradiation (db(A))	33	42	44	46	51	56
	Extraction duct (dB(A))	34	43	45	48	50	57
	Insulation duct (dB(A))	46	51	59	62	65	66

### CHARACTERISTIC CURVE

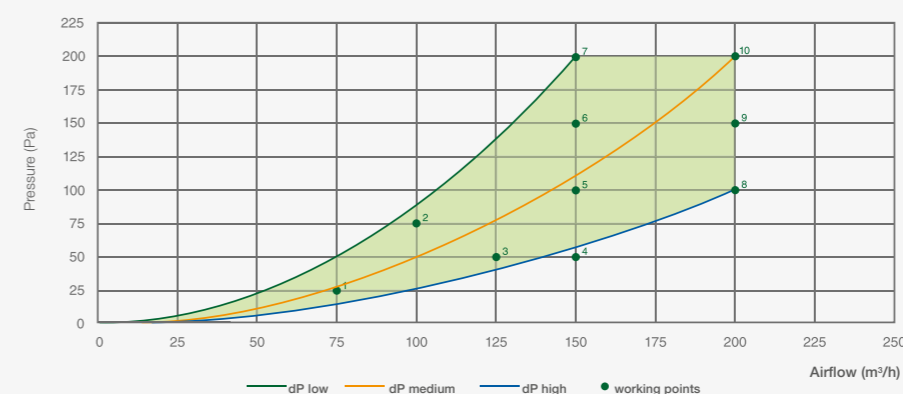

Working points	AIRFLOW (m³/h)	PRESSURE (Pa)	POWER (W)	SFP (W/l/s)
1	75	25	12.61	0.61
2	100	75	25.31	0.91
3	125	50	29.16	0.84
4	150	50	39.20	0.94
5	150	100	49.65	1.19
6	150	150	60.92	1.46
7	150	200	72.60	1.74
8	200	100	81.33	1.46
9	200	150	93.10	1.68
10	200	200	106.48	1.92

# SIBER DF EVO 2 Enthalpic Mode



SIBER® DF EVO 2 Enthalpic Mode					
Supply voltage	230V/ 50 Hz				
Firewall protection	IP 40				
Dimensions (l x h x p)	1000 x 600 x 210 mm				
Connection's diameter	Ø 160				
Condensation drain diameter	1/2"				
Weight	24 Kg				
Filter's type	Coarse 65% (G4)				
Fan position (standard)					Boost mode
Wireless intelligent multi-controller (optional)	0	1	2	3	Max
Airflow (m³/h)	30	75	100	150	200

Acoustic level SIBER® DF EVO 2 Enthalpic Mode							
Airflow (m³/h)		75	125	150	200		
Acoustic level Lw (A)	Static pressure (Pa)	25	50	50	100	150	200
	Box irradiation (db(A))	33	42	44	46	51	56
	Extraction duct (dB(A))	34	43	45	48	50	57
	Insulation duct (dB(A))	46	51	59	62	65	66

# Complementary products

## FILTERS



ACTIVATED CARBON FILTER
F7 FILTER DF (1 FIL. ISO EPM1 55%)
F9 FILTER DF (1 FIL. ISO EPM1 80%)
G4 FILTER DF (1 FIL. COARSE 65%)
G4/F7 FILTERS DF (COARSE 65% + EPM155%)
G4/F9 FILTERS DF (COARSE 65% + EPM180%)

## CHARACTERISTIC CURVE

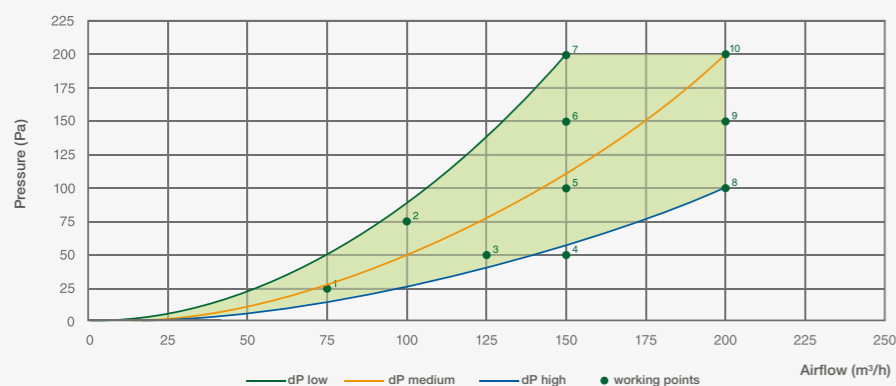

Working points	AIRFLOW (m³/h)	PRESSURE (Pa)	POWER (W)	SFP (W/l/s)
1	75	25	12.61	0.61
2	100	75	25.31	0.91
3	125	50	29.16	0.84
4	150	50	39.20	0.94
5	150	100	49.65	1.19
6	150	150	60.92	1.46
7	150	200	72.60	1.74
8	200	100	81.33	1.46
9	200	150	93.10	1.68
10	200	200	106.48	1.92

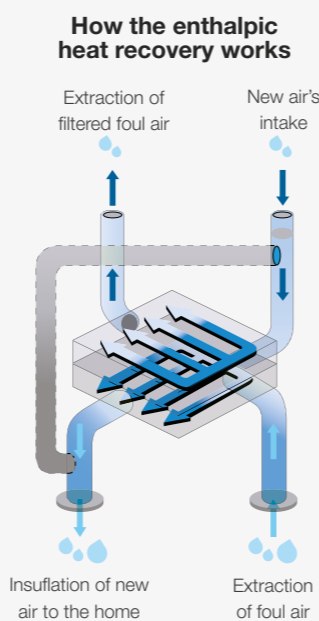

## CONTROL ACCESORIES

WIRELESS REMOTE - 4 POSITIONS



WIRELESS MULTICONTROL REMOTE



WIRELESS HUMIDITY SENSOR



WIRELESS CO2 SENSOR



**Siber®**  
muy cerca de ti  
Consúltenos su proyecto  
[www.siberzone.es](http://www.siberzone.es)



*Eco-friendly ventilation systems & efficient air treatment.*



**Ventilación inteligente**



**Siber Zone, S.L.**  
Fábrica y Oficinas Centrales:  
Apdo. de Correos n. 9  
C/ Can Macià n. 2  
08520 Les Franqueses del Vallès  
Barcelona-España

Tel. 902 02 72 14  
Int. 00 34 938 616 261  
Fax. 902 02 72 16  
Int. 00 34 937 814 108  
[siber@siberzone.es](mailto:siber@siberzone.es)  
[www.siberzone.es](http://www.siberzone.es)

Nor the partial and complete reproduction of the content within this publication is allowed without the express consent of the owner.

Siber Zone, S.L. reserves its right to realize any kind of technical modification of the equipments and additional elements without previous notice.